



# SPIRIT<sup>®</sup>

## GRILL OWNER'S GUIDE

E-210<sup>™</sup> · S-210<sup>™</sup> · E-310<sup>™</sup> · SP-310<sup>™</sup> LP

**YOU MUST READ THIS OWNER'S GUIDE  
BEFORE OPERATING YOUR GAS GRILL.**

### REGISTER YOUR GRILL

Thank you for purchasing a Weber<sup>®</sup> grill. Take a few minutes to protect your investment by registering your grill online at [www.weber.com](http://www.weber.com). Reference the serial number on the front cover of this owner's guide.



#### ⚠ DANGER

If you smell gas:

- 1) Shut off gas to the appliance.
- 2) Extinguish any open flames.
- 3) Open lid.
- 4) If odor continues, keep away from the appliance and immediately call your gas supplier or your fire department.

Leaking gas may cause a fire or explosion which can cause serious bodily injury, death, or damage to property.

Carefully follow all leak-check procedures in this Owner's Guide prior to grill operation. Do this even if the grill was dealer-assembled.

Do not ignite this appliance without first reading the burner ignition sections of this manual.

#### ⚠ WARNING

- 1) Do not store or use gasoline or other flammable liquids or vapors in the vicinity of this or any other appliance.
- 2) An LP tank not connected for use shall not be stored in the vicinity of this or any other appliance.

**THIS GAS APPLIANCE IS  
DESIGNED FOR OUTDOOR  
USE ONLY.**

**NOTICE TO INSTALLER:** These instructions must be left with the owner, who should keep them for future use.



**48615**

US - ENGLISH  
07/23/14

## WARNINGS

### ⚠ DANGER

Failure to follow the DANGERS, WARNINGS and CAUTIONS contained in this Owner's Guide may result in serious bodily injury or death, or may result in a fire or an explosion causing damage to property.

### WARNINGS:

- ⚠ Improper assembly of grill may be dangerous. Please follow the assembly instructions carefully.
- ⚠ Do not use this grill unless all parts are in place. The grill must be properly assembled according to the assembly instructions.
- ⚠ Your Weber® gas grill should never be used by children. Accessible parts of the grill may be very hot. Keep young children away while grill is in use.
- ⚠ Exercise caution when using your Weber® gas grill. It will be hot during cooking or cleaning, and should never be left unattended, or moved while in operation.
- ⚠ Do not use charcoal or lava rock in your Weber® gas grill.
- ⚠ While igniting the grill or cooking, never lean over open grill.
- ⚠ Never place hands or fingers on the front edge of the cookbox when the grill is hot or the lid is open.
- ⚠ Do not attempt to disconnect the gas regulator and hose assembly or any gas fitting while your grill is in operation.
- ⚠ Use heat-resistant barbecue mitts or gloves when operating grill.
- ⚠ Use the pressure regulator and hose assembly that is supplied with your Weber® gas grill.
- ⚠ Should the burners go out while grill is in operation, turn all gas valves off. Open the lid and wait five minutes before attempting to relight grill, using the igniting instructions.
- ⚠ Do not use the grill within 24 inches (61 cm) of combustible materials. This includes the top, bottom, back or sides of the grill.
- ⚠ Do not build this model of grill in any built-in or slide-in construction. Ignoring this WARNING could cause a fire or an explosion that can damage property and cause serious bodily injury or death.
- ⚠ Do not store an extra (spare) or disconnected liquid propane tank under or near this grill.
- ⚠ After a period of storage and/or nonuse, the Weber® gas grill should be checked for gas leaks and burner obstructions before use. See instructions in this Owner's Guide for correct procedures.
- ⚠ Do not operate the Weber® gas grill if there is a gas leak present.
- ⚠ Do not use a flame to check for gas leaks.
- ⚠ Do not put a grill cover or anything flammable on, or in the storage area under the grill while grill is in operation or is hot.
- ⚠ Liquid propane gas is not natural gas. The conversion or attempted use of natural gas in a liquid propane gas unit or liquid propane gas in a natural gas unit is dangerous and will void your warranty.
- ⚠ Keep any electrical supply cord and the fuel supply hose away from any heated surfaces.
- ⚠ Do not enlarge valve orifices or burner ports when cleaning the valves or burners.
- ⚠ The Weber® gas grill should be thoroughly cleaned on a regular basis.
- ⚠ A dented or rusty liquid propane tank may be hazardous and should be checked by your liquid propane supplier. Do not use a liquid propane tank with a damaged valve.
- ⚠ Although your liquid propane tank may appear to be empty, gas may still be present, and the tank should be transported and stored accordingly.
- ⚠ If you see, smell or hear the hiss of gas escaping from the liquid propane tank:
  1. Move away from liquid propane tank.
  2. Do not attempt to correct the problem yourself.
  3. Call your fire department.
- ⚠ Should a grease fire occur, turn off all burners and leave lid closed until fire is out.

### ADDITIONAL WARNINGS FOR STATE OF CALIFORNIA:

- ⚠ Combustion byproducts produced when using this product contain chemicals known to the state of California to cause cancer, birth defects, or other reproductive harm.
- ⚠ Proposition 65 Warning: Handling the brass material on this product exposes you to lead, a chemical known to the state of California to cause cancer, birth defects or other reproductive harm. (Wash hands after handling this product.)

# WARRANTY

Thank you for purchasing a WEBER® product. Weber-Stephen Products LLC, 200 East Daniels Road, Palatine, Illinois 60067-6266 ("Weber") prides itself on delivering a safe, durable, and reliable product.

This is Weber's Voluntary Warranty provided to you at no extra charge. It contains the information you will need to have your WEBER® product repaired in the unlikely event of a failure or defect.

**Pursuant to applicable laws, the customer has several rights in case the product is defective. Those rights include supplementary performance or replacement, abatement of the purchasing price, and compensation. In the European Union, for example, this would be a two-year statutory warranty starting on the date of the handover of the product. These and other statutory rights remain unaffected by this warranty provision. In fact, this warranty grants additional rights to the Owner that are independent from statutory warranty provisions.**

## WEBER'S VOLUNTARY WARRANTY

Weber warrants, to the purchaser of the WEBER® product (or in the case of a gift or promotional situation, the person for whom it was purchased as a gift or promotional item), that the WEBER® product is free from defects in material and workmanship for the period(s) of time specified below when assembled and operated in accordance with the accompanying Owner's Guide. (Note: If you lose or misplace your WEBER® Owner's Guide, a replacement is available online at [www.weber.com](http://www.weber.com), or such country-specific website to which Owner may be redirected.) Under normal, private single family home or apartment use and maintenance, Weber agrees within the framework of this warranty to repair or replace defective parts within the applicable time periods, limitations and exclusions listed below. TO THE EXTENT ALLOWABLE BY APPLICABLE LAW, THIS WARRANTY IS EXTENDED ONLY TO THE ORIGINAL PURCHASER AND IS NOT TRANSFERABLE TO SUBSEQUENT OWNERS, EXCEPT IN THE CASE OF GIFTS AND PROMOTIONAL ITEMS AS NOTED ABOVE.

## OWNER'S RESPONSIBILITIES UNDER THIS WARRANTY

To ensure trouble-free warranty coverage, it is important (but it is not required) that you register your WEBER® product online at [www.weber.com](http://www.weber.com), or such country-specific website to which Owner may be redirected. Please also retain your original sales receipt and/or invoice. Registering your WEBER® product confirms your warranty coverage and provides a direct link between you and Weber in case we need to contact you.

The above warranty only applies if the Owner takes reasonable care of the WEBER® product by following all assembly instructions, usage instructions, and preventative maintenance as outlined in the accompanying Owner's Guide, unless the Owner can prove that the defect or failure is independent of non-compliance with the above mentioned obligations. If you live in a coastal area, or have your product located near a pool, maintenance includes regular washing and rinsing of the exterior surfaces as outlined in the accompanying Owner's Guide.

## WARRANTY HANDLING / EXCLUSION OF WARRANTY

If you believe that you have a part which is covered by this Warranty, please contact Weber Customer Service using the contact information on our website ([www.weber.com](http://www.weber.com), or such country-specific website to which Owner may be redirected). Weber will, upon investigation, repair or replace (at its option) a defective part that is covered by this Warranty. In the event that repair or replacement are not possible, Weber may choose (at its option) to replace the grill in question with a new grill of equal or greater value. Weber may ask you to return parts for inspection, shipping charges to be pre-paid.

This WARRANTY lapses if there are damages, deteriorations, discolorations and/or rust for which Weber is not responsible caused by:

- Abuse, misuse, alteration, modification, misapplication, vandalism, neglect, improper assembly or installation, and failure to properly perform normal and routine maintenance;
- Insects (such as spiders) and rodents (such as squirrels), including but not limited to damage to burner tubes and/or gas hoses;
- Exposure to salt air and/or chlorine sources such as swimming pools and hot tubs/spas;
- Severe weather conditions such as hail, hurricanes, earthquakes, tsunamis or surges, tornadoes or severe storms.

The use and/or installation of parts on your WEBER® product that are not genuine Weber parts will void this Warranty, and any damages that result hereby are not covered by this Warranty. Any conversion of a gas grill not authorized by Weber and performed by a Weber authorized service technician will void this Warranty.

The grills illustrated in this Owner's Guide may vary slightly from the model purchased.

## PRODUCT WARRANTY PERIODS

Cookbox:  
10 years, no rust through/burn through  
2 years paint excluding fading or discoloration

Lid assembly:  
10 years, no rust through/burn through

Stainless steel burner tubes:  
10 years, no rust through/burn through

Stainless steel cooking grates:  
5 years, no rust through/burn through

Stainless steel Flavorizer® bars:  
5 years, no rust through/burn through

Porcelain-enameled cast iron cooking grates:  
5 years, no rust through/burn through

All remaining parts:  
2 years

## DISCLAIMERS

**APART FROM THE WARRANTY AND DISCLAIMERS AS DESCRIBED IN THIS WARRANTY STATEMENT, THERE ARE EXPLICITLY NO FURTHER WARRANTY OR VOLUNTARY DECLARATIONS OF LIABILITY GIVEN HERE WHICH GO BEYOND THE STATUTORY LIABILITY APPLYING TO WEBER. THE PRESENT WARRANTY STATEMENT ALSO DOES NOT LIMIT OR EXCLUDE SITUATIONS OR CLAIMS WHERE WEBER HAS MANDATORY LIABILITY AS PRESCRIBED BY STATUTE.**

**NO WARRANTIES SHALL APPLY AFTER THE APPLICABLE PERIODS OF THIS WARRANTY. NO OTHER WARRANTIES GIVEN BY ANY PERSON, INCLUDING A DEALER OR RETAILER, WITH RESPECT TO ANY PRODUCT (SUCH AS ANY "EXTENDED WARRANTIES"), SHALL BIND WEBER. THE EXCLUSIVE REMEDY OF THIS WARRANTY IS REPAIR OR REPLACEMENT OF THE PART OR PRODUCT.**

**IN NO EVENT UNDER THIS VOLUNTARY WARRANTY SHALL RECOVERY OF ANY KIND BE GREATER THAN THE AMOUNT OF THE PURCHASE PRICE OF THE WEBER PRODUCT SOLD.**

**YOU ASSUME THE RISK AND LIABILITY FOR LOSS, DAMAGE, OR INJURY TO YOU AND YOUR PROPERTY AND/OR TO OTHERS AND THEIR PROPERTY ARISING OUT OF THE MISUSE OR ABUSE OF THE PRODUCT OR FAILURE TO FOLLOW INSTRUCTIONS PROVIDED BY WEBER IN THE ACCOMPANYING OWNER'S GUIDE.**

**PARTS AND ACCESSORIES REPLACED UNDER THIS WARRANTY ARE WARRANTED ONLY FOR THE BALANCE OF THE ABOVE MENTIONED ORIGINAL WARRANTY PERIOD(S).**

**THIS WARRANTY APPLIES TO PRIVATE SINGLE FAMILY HOME OR APARTMENT USE ONLY AND DOES NOT APPLY TO WEBER GRILLS USED IN COMMERCIAL, COMMUNAL OR MULTI-UNIT SETTINGS SUCH AS RESTAURANTS, HOTELS, RESORTS, OR RENTAL PROPERTIES.**

**WEBER MAY FROM TIME TO TIME CHANGE THE DESIGN OF ITS PRODUCTS. NOTHING CONTAINED IN THIS WARRANTY SHALL BE CONSTRUED AS OBLIGATING WEBER TO INCORPORATE SUCH DESIGN CHANGES INTO PREVIOUSLY MANUFACTURED PRODUCTS, NOR SHALL SUCH CHANGES BE CONSTRUED AS AN ADMISSION THAT PREVIOUS DESIGNS WERE DEFECTIVE.**

**WEBER-STEPHEN PRODUCTS LLC**  
Customer Service Center  
2900 Golf Road  
Rolling Meadows, IL 60008  
U.S.A.

**For replacement parts, call:**  
1-800-446-1071

# TABLE OF CONTENTS

WARNINGS .....	2
WARRANTY .....	3
TABLE OF CONTENTS .....	3
SPIRIT® E/S-210™ LP EXPLODED VIEW .....	4
SPIRIT® E-310™ LP EXPLODED VIEW .....	6
SPIRIT® SP-310™ LP EXPLODED VIEW .....	8
IMPORTANT INFORMATION ABOUT LP GAS ....	10
WHAT IS LP GAS? .....	10
SAFE HANDLING TIPS FOR LIQUID PROPANE GAS TANKS .....	10
STORAGE AND/OR NONUSE .....	10
US INSTALLATION CODES .....	10
MEXICO INSTALLATION CODES .....	10
CANADIAN INSTALLATION CODES .....	10
US LP TANK REQUIREMENTS .....	10
CANADIAN LP TANK REQUIREMENTS .....	10
IMPORTANT INFORMATION ABOUT LP GAS CONNECTIONS .....	11
WHAT IS A REGULATOR? .....	11
REGULATOR CONNECTIONS .....	11
LP TANK INSTALLATION AND REMOVAL .....	12
FUELING YOUR GRILL .....	12
INSTALLING THE LP TANK .....	12
FUEL LEVEL .....	13
REMOVING THE LIQUID PROPANE TANK FOR REFILLING OR REPLACEMENT .....	13
FILLING THE LP GAS TANK .....	13
PREPARING TO USE YOUR GRILL .....	14
WHAT IS A LEAK CHECK? .....	14
PARTIAL DISASSEMBLY OF YOUR GRILL FOR A LEAK CHECK .....	14
CHECKING FOR GAS LEAKS .....	15
GRILLING TIPS & HELPFUL HINTS .....	16
TIPS & HINTS .....	16
PREHEATING .....	16
COVERED COOKING .....	16
FLAVORIZER® SYSTEM .....	16
DRIPPINGS AND GREASE .....	16
SAFETY CHECKS BEFORE USING YOUR GRILL. .	17
SAFETY FIRST .....	17
SLIDE-OUT GREASE TRAY .....	17
CATCH PAN AND DISPOSABLE DRIP PAN .....	17
HOSE INSPECTION .....	17
MAIN BURNER IGNITION & USAGE .....	18
METHODS OF BURNER IGNITION .....	18
MAIN BURNER IGNITION .....	18
TO EXTINGUISH BURNER .....	18
TROUBLESHOOTING .....	20
GENERAL TROUBLESHOOTING .....	20
CLEANING FOR GREAT MEALS .....	21
MEAL-TO-MEAL MAINTENANCE .....	21
MAINTAINING THE GREASE MANAGEMENT SYSTEM .....	21
PREHEATING THE GRILL .....	21
CLEANING THE COOKING GRATE .....	21
CLEANING FOR SAFETY .....	22
CLEANING THE BURNER TUBES .....	22
CLEAN THE BURNER TUBE PORTS .....	22
CLEAN THE SPIDER/INSECT SCREENS .....	23
CALL CUSTOMER SERVICE .....	23
CLEANING FOR PERFORMANCE .....	24
PREVENTATIVE MAINTENANCE .....	24
CLEANING THE LID .....	24
CLEANING THE COOKING GRATES .....	24
CLEANING THE FLAVORIZER® BARS .....	24
CLEANING THE COOKBOX .....	25
CLEANING THE GREASE MANAGEMENT SYSTEM .....	25
CLEANING THE OUTSIDE OF GRILLS THAT ARE IN UNIQUE ENVIRONMENTS .....	25
STORAGE AND/OR NONUSE .....	25
IGNITION SYSTEM MAINTENANCE .....	26
MAINTAINING THE ELECTRONIC CROSSOVER® IGNITION SYSTEM .....	26



**SPIRIT® E/S-210™ LP  
EXPLODED VIEW LIST**

1. Thermometer and Bezel
2. Logo Plate
3. Shroud Assembly
4. Warming Rack
5. Crossover® Burner Tube
6. Igniter Electrode
7. Burner Tube
8. Cookbox
9. Disposable Drip Pan
10. Left Frame Panel
11. Catch Pan
12. Catch Pan Holder
13. Matchstick Holder
14. Igniter Module
15. Control Knob
16. Igniter Button
17. Control Panel
18. Front Cross Brace
19. Door
20. Door Handle
21. Shroud Hardware
22. Cooking Grate
23. Flavorizer® Bar
24. Fold-Down Side Table
25. Fold-Down Assembly
26. Rear Cross Brace
27. Rear Panel
28. Manifold
29. Manifold Hose
30. Bulkhead
31. Hose & Regulator
32. Right Frame Panel
33. Tank Glide
34. Tank Scale
35. Slide-Out Grease Tray
36. Bottom Panel
37. Caster
38. Locking Caster

**SPIRIT® E/S-210™ LP  
LISTA DEL DIAGRAMA DE DESPIECE**

1. Termómetro y bisel
2. Placa del logotipo
3. Ensamblaje de la cubierta
4. Rejilla para calentar
5. Tubo del quemador Crossover®
6. Electrodo de encendido
7. Tubo del quemador
8. Caja de cocción
9. Bandeja de goteo desechable
10. Panel izquierdo del bastidor
11. Plato recolector
12. Soporte del plato recolector
13. Portacerillos
14. Módulo de encendido
15. Perilla de control
16. Botón de encendido
17. Tablero de control
18. Refuerzo transversal delantero
19. Puerta
20. Asa de la puerta
21. Accesorios de la cubierta
22. Parrilla de cocción
23. Barra Flavorizer®
24. Mesa lateral
25. Ensamble plegable
26. Refuerzo transversal posterior
27. Panel posterior
28. Múltiple
29. Manguera del múltiple
30. Bloque de conexiones
31. Manguera y regulador
32. Panel derecho del bastidor
33. Deslizadora del tanque
34. Báscula del tanque
35. Bandeja deslizante de grasa
36. Panel inferior
37. Rueda giratoria
38. Rueda giratoria con bloqueo

**SPIRIT® E/S-210™ LP  
LISTE DE LA VUE ÉCLATÉE**

1. Thermomètre et bec
2. Plaque du logo
3. Assemblage du châssis
4. Grille de maintien au chaud
5. Tube du brûleur Crossover®
6. Électrode de l'allumeur
7. Tube du brûleur
8. Boîtier de cuisson
9. Égouttoir jetable
10. Panneau du cadre gauche
11. Égouttoir
12. Support pour égouttoir
13. Porte-allumette
14. Module de l'allumeur
15. Bouton de commande
16. Bouton de l'allumeur
17. Panneau de commande
18. Croisillon avant
19. Port
20. Poignée de porte
21. Quincaillerie du châssis
22. Grille de cuisson
23. Barre Flavorizer®
24. Tablette latérale
25. Assemblage pliable
26. Croisillon arrière
27. Panneau arrière
28. Collecteur
29. Tuyau du collecteur
30. Cloison
31. Tuyau & régulateur
32. Panneau du châssis droit
33. Glissière du réservoir de gaz
34. Échelle du réservoir de gaz
35. Plateau de récupération des graisses amovible
36. Panneau inférieur
37. Roulette
38. Roulette à verrouillage

SPIRIT® E-310™ LP EXPLODED VIEW · DIAGRAMA DE DESPIECE · VUE ECLATEE

Spirit® E-310™\_LP\_US\_070114

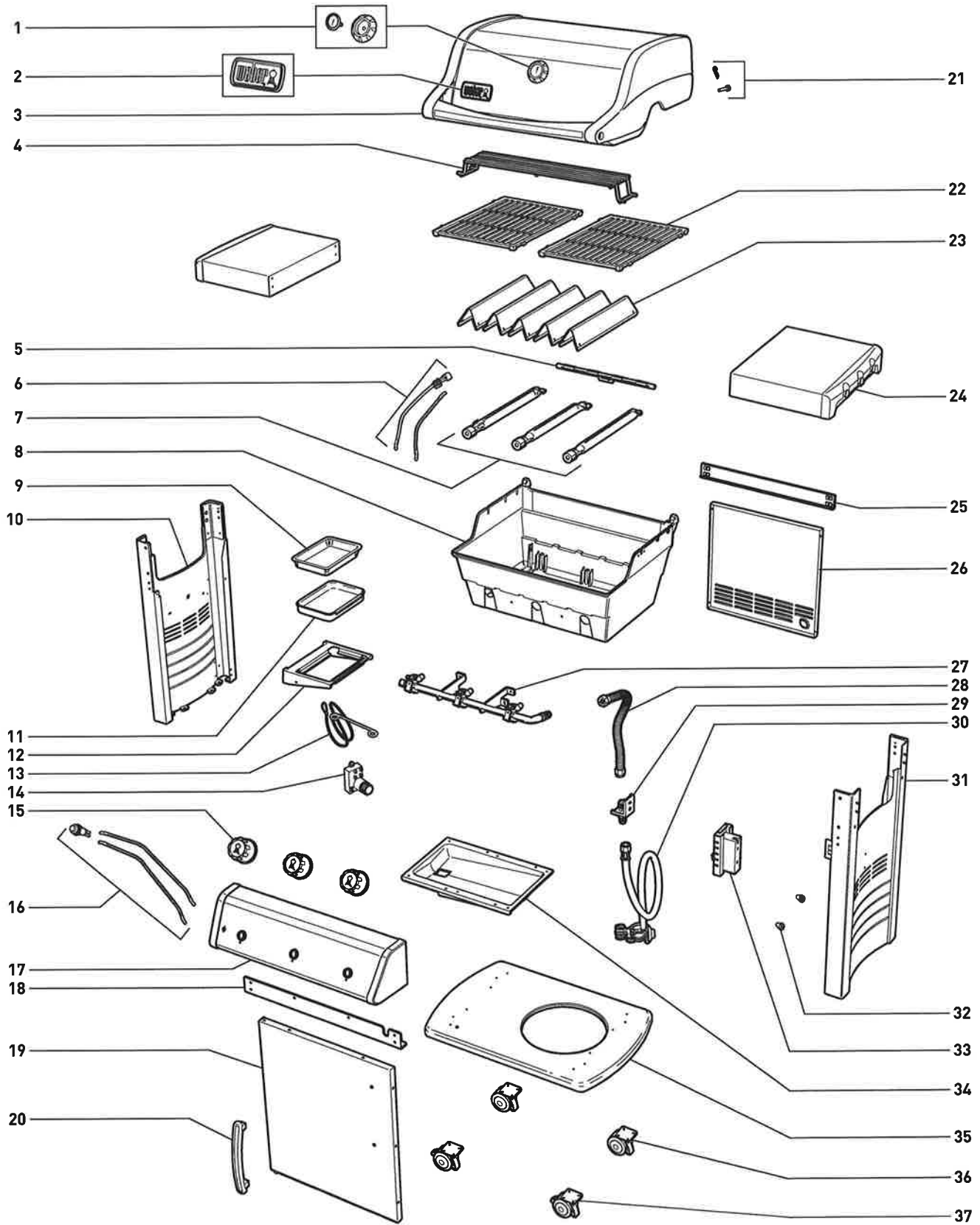

**SPIRIT® E-310™ LP  
EXPLODED VIEW LIST**

1. Thermometer and Bezel
2. Logo Plate
3. Shroud Assembly
4. Warming Rack
5. Crossover® Burner Tube
6. Igniter Electrode
7. Burner Tube
8. Cookbox
9. Disposable Drip Pan
10. Left Frame Panel
11. Catch Pan
12. Catch Pan Holder
13. Matchstick Holder
14. Igniter Module
15. Control Knob
16. Igniter Button
17. Control Panel
18. Front Cross Brace
19. Door
20. Door Handle
21. Shroud Hardware
22. Cooking Grate
23. Flavorizer® Bar
24. Side Table
25. Rear Cross Brace
26. Rear Panel
27. Manifold
28. Manifold Hose
29. Bulkhead
30. Hose & Regulator
31. Right Frame Panel
32. Tank Glide
33. Tank Scale
34. Slide-Out Grease Tray
35. Bottom Panel
36. Caster
37. Locking Caster

**SPIRIT® E-310™ LP  
LISTA DEL DIAGRAMA DE DESPIECE**

1. Termómetro y bisel
2. Placa del logotipo
3. Ensamblaje de la cubierta
4. Rejilla para calentar
5. Tubo del quemador Crossover®
6. Electrodo de encendido
7. Tubo del quemador
8. Caja de cocción
9. Bandeja de goteo desechable
10. Panel izquierdo del bastidor
11. Plato recolector
12. Soporte del plato recolector
13. Portacerillos
14. Módulo de encendido
15. Perilla de control
16. Botón de encendido
17. Tablero de control
18. Refuerzo transversal delantero
19. Puerta
20. Asa de la puerta
21. Accesorios de la cubierta
22. Parrilla de cocción
23. Barra Flavorizer®
24. Mesa lateral
25. Refuerzo transversal posterior
26. Panel posterior
27. Múltiple
28. Manguera del múltiple
29. Bloque de conexiones
30. Manguera y regulador
31. Panel derecho del bastidor
32. Deslizadora del tanque
33. Báscula del tanque
34. Bandeja deslizante de grasa
35. Panel inferior
36. Rueda giratoria
37. Rueda giratoria con bloqueo

**SPIRIT® E-310™ LP  
LISTE DE LA VUE ÉCLATÉE**

1. Thermomètre et bec
2. Plaque du logo
3. Assemblage du châssis
4. Grille de maintien au chaud
5. Tube du brûleur Crossover®
6. Électrode de l'allumeur
7. Tube du brûleur
8. Boîtier de cuisson
9. Égouttoir jetable
10. Panneau du cadre de gauche
11. Égouttoir
12. Support de l'égouttoir
13. Porte-allumette
14. Module de l'allumeur
15. Bouton de commande
16. Bouton de l'allumeur
17. Panneau de commande
18. Croisillon avant
19. Porte
20. Poignée de porte
21. Quincaillerie du châssis
22. Grille de cuisson
23. Barre Flavorizer®
24. Tablette latérale
25. Croisillon arrière
26. Panneau arrière
27. Collecteur
28. Tuyau du collecteur
29. Cloison
30. Tuyau & régulateur
31. Panneau du châssis droit
32. Glissière du réservoir de gaz
33. Échelle du réservoir de gaz
34. Plateau de récupération des graisses amovible
35. Panneau inférieur
36. Roulette
37. Roulette à verrouillage

**SPIRIT® SP-310™ LP EXPLODED VIEW · DIAGRAMA DE DESPIECE · VUE ECLATEE**

Spirit® SP-310™\_LP\_US\_070114

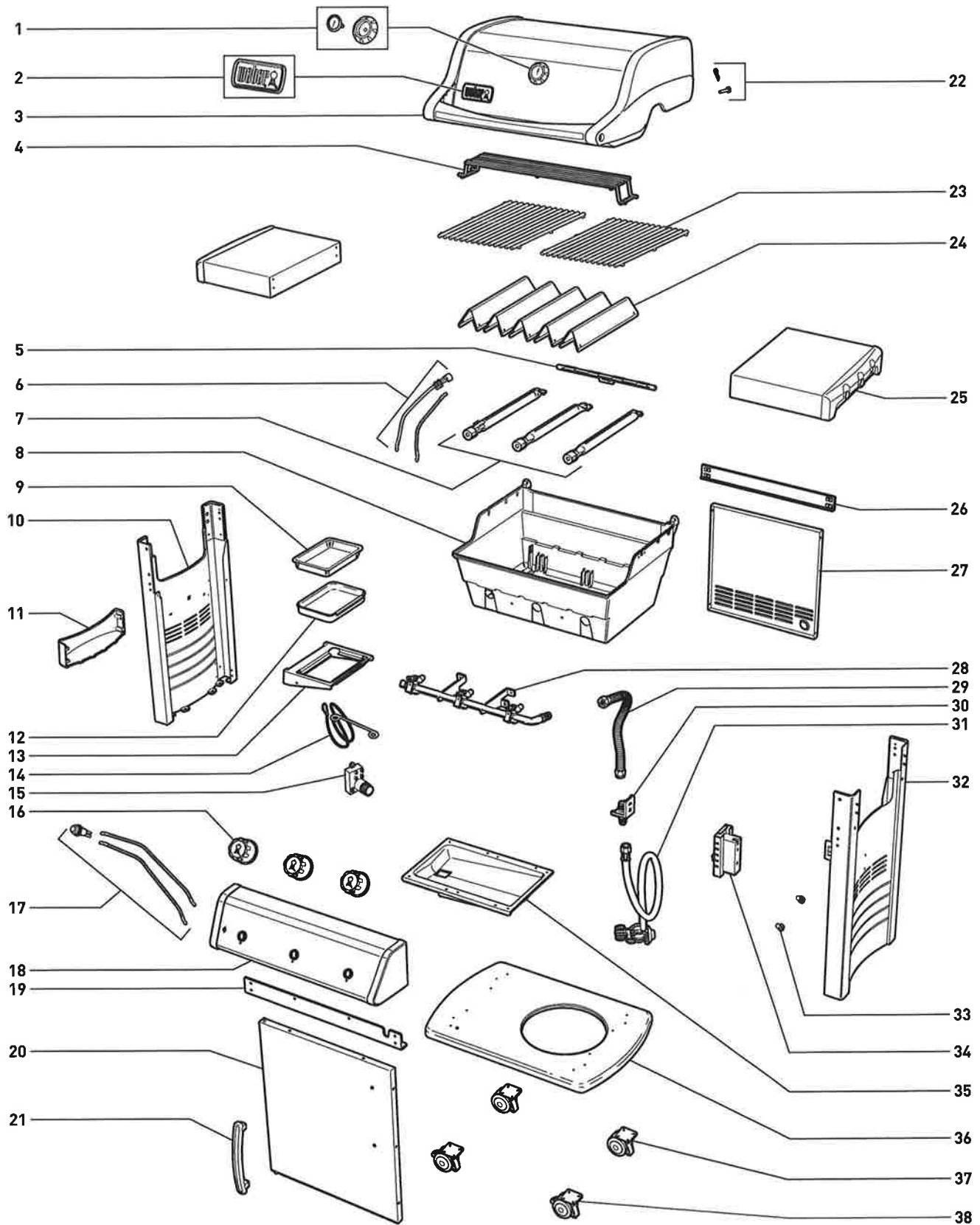

**SPIRIT® SP-310™ LP  
EXPLODED VIEW LIST**

1. Thermometer and Bezel
2. Logo Plate
3. Shroud Assembly
4. Warming Rack
5. Crossover® Burner Tube
6. Igniter Electrode
7. Burner Tube
8. Cookbox
9. Disposable Drip Pan
10. Left Frame Panel
11. Condiment Basket
12. Catch Pan
13. Catch Pan Holder
14. Matchstick Holder
15. Igniter Module
16. Control Knob
17. Igniter Button
18. Control Panel
19. Front Cross Brace
20. Door
21. Door Handle
22. Shroud Hardware
23. Cooking Grate
24. Flavorizer® Bar
25. Side Table
26. Rear Cross Brace
27. Rear Panel
28. Manifold
29. Manifold Hose
30. Bulkhead
31. Hose & Regulator
32. Right Frame Panel
33. Tank Glide
34. Tank Scale
35. Slide-Out Grease Tray
36. Bottom Panel
37. Caster
38. Locking Caster

**SPIRIT® SP-310™ LP  
LISTA DEL DIAGRAMA DE DESPIECE**

1. Termómetro y bisel
2. Placa del logotipo
3. Ensamblaje de la cubierta
4. Rejilla para calentar
5. Tubo del quemador Crossover®
6. Electrodo de encendido
7. Tubo del quemador
8. Caja de cocción
9. Bandeja de goteo desechable
10. Panel izquierdo del bastidor
11. Cesta para los condimentos
12. Plato recolector
13. Soporte del plato recolector
14. Portacerillos
15. Módulo de encendido
16. Perilla de control
17. Botón de encendido
18. Tablero de control
19. Refuerzo transversal delantero
20. Puerta
21. Asa de la puerta
22. Accesorios de la cubierta
23. Parrilla de cocción
24. Barra Flavorizer®
25. Mesa lateral
26. Refuerzo transversal posterior
27. Panel posterior
28. Múltiple
29. Manguera del múltiple
30. Bloque de conexiones
31. Manguera y regulador
32. Panel derecho del bastidor
33. Deslizadora del tanque
34. Báscula del tanque
35. Bandeja deslizante de grasa
36. Panel inferior
37. Rueda giratoria
38. Rueda giratoria con bloqueo

**SPIRIT® SP-310™ LP  
LISTE DE LA VUE ÉCLATÉE**

1. Thermomètre et bec
2. Plaque du logo
3. Assemblage du châssis
4. Grille de maintien au chaud
5. Tube du brûleur Crossover®
6. Électrode de l'allumeur
7. Tube du brûleur
8. Boîtier de cuisson
9. Égouttoir jetable
10. Panneau du châssis gauche
11. Panier à condiments
12. Égouttoir
13. Support pour égouttoir
14. Porte-allumette
15. Module de l'allumeur
16. Bouton de commande
17. Bouton de l'allumeur
18. Panneau de commande
19. Croisillon avant
20. Porte
21. Poignée de porte
22. Quincaillerie du châssis
23. Grille de cuisson
24. Barre Flavorizer®
25. Tablette latérale
26. Croisillon arrière
27. Panneau arrière
28. Collecteur
29. Tuyau du collecteur
30. Cloison
31. Tuyau & régulateur
32. Panneau du châssis droit
33. Glissière du réservoir de gaz
34. Échelle du réservoir de gaz
35. Plateau de récupération des graisses amovible
36. Panneau inférieur
37. Roulette
38. Roulette à verrouillage

# IMPORTANT INFORMATION ABOUT LP GAS

## WHAT IS LP GAS?

Liquefied petroleum gas, also called LP, LP gas, liquid propane, or simply propane or butane, is the flammable, petroleum-based product used to fuel your grill. It is a gas at moderate temperatures and pressure when it is not contained. But at moderate pressure inside a container, such as a tank, LP is a liquid. As pressure is released from the tank, the liquid readily vaporizes and becomes LP gas.

- LP has an odor similar to natural gas. You should be aware of this odor.
- LP is heavier than air. Leaking LP gas may collect in low areas and resist dispersion.

## SAFE HANDLING TIPS FOR LIQUID PROPANE GAS TANKS

There are various guidelines and safety factors that you need to keep in mind when using liquid propane (LP) gas. Carefully follow these instructions before using your Weber® gas grill.

- Always close the tank valve before disconnecting regulator.
- Do not use a damaged LP tank. A dented or rusty LP tank or an LP tank with a damaged valve may be hazardous and should be replaced with a new tank immediately.
- Treat "empty" LP tanks with the same care as you treat full tanks. Even when an LP tank is empty of liquid, there may still be gas pressure inside the tank.
- The LP tank must be installed, transported, and stored in an upright position. LP tanks should not be dropped or handled roughly.
- Never store or transport the LP tank where temperatures can reach 125° F (the tank will become too hot to hold by hand). For example: do not leave the LP tank in a car on a hot day.
- Leak test the fitting where the regulator connects to the LP tank each time a reconnection occurs. For example: test each time the LP tank is refilled and reinstalled.
- LP tanks must be kept out of reach of children.

## STORAGE AND/OR NONUSE

For grills that have been stored or left unused for a while, it is important to follow these guidelines:

- The gas must be turned off at the LP tank when the Weber® gas grill is not in use.
- ⚠ **WARNING: Make sure that the LP tank valve is closed when the grill is not in use. Close by turning valve clockwise.**
- If storing the Weber® gas grill indoors, first DISCONNECT the gas supply and store the LP tank outdoors in a well-ventilated space.
- ⚠ **CAUTION: Place dust cap on tank valve outlet whenever the tank is not in use. Only install the type of dust cap on the tank valve outlet that is provided with the tank valve. Other types of caps or plugs may result in leakage of propane.**
- Do not store a disconnected LP tank in a building, garage, or any other enclosed area.
- If you do not disconnect the LP tank from the Weber® gas grill, be sure to keep both the grill and the tank outdoors in a well-ventilated area.
- The Weber® gas grill should be checked for gas leaks and any obstructions in the burner tubes before it is used. (Refer to "ANNUAL MAINTENANCE.")
- Check that the areas under the control panel and the slide-out grease tray are free from debris that might obstruct the flow of combustion or ventilation air.
- The spider/insect screens should also be checked for any obstructions. (Refer to "ANNUAL MAINTENANCE.")

## US INSTALLATION CODES

Installation must conform with local codes or, in the absence of local codes, with either the National Fuel Gas Code, ANSI Z223.1/NFPA 54, Natural Gas and Propane Installation Code, CSA B149.1; or Propane Storage and Handling Code, B149.2; or the Standard for Recreational Vehicles, ANSI A 119.2/NFPA 1192, and CSA Z240 RV Series, Recreational Vehicle Code, as applicable.

## MEXICO INSTALLATION CODES

If there are local codes that apply to portable gas grills, you must comply with the latest edition of NOM.

## CANADIAN INSTALLATION CODES

These instructions, while generally acceptable, do not necessarily comply with the Canadian installation codes, particularly with piping above and below ground. In Canada, the installation of this appliance must comply with local codes and/or the latest edition of Standard CAN/CSA-B149.2 (Propane Storage and Handling Code).

## US LP TANK REQUIREMENTS

- Check to be sure that tanks have a D.O.T. certification **(1)**, and that the testing date **(2)** is within five years of current use. Your LP gas supplier can do this for you.
  - All LP tank supply systems must include a collar to protect the tank valve.
  - The LP tank must be a 20-lb. size, approximately 18¼ inches high and 12¼ inches in diameter.
  - The tank must be constructed and marked in accordance with Specifications for LP - Gas Tanks (Tanks) of the U.S. Department of Transportation (D.O.T.) or the National Standard of Canada, CAN/CSA-B339, Tanks (Tanks), Spheres and Tubes or Transportation of Dangerous Goods; and Commission, as applicable.
- ⚠ **WARNING: The liquid propane tank used with your grill must have a listed OPD (Overfilling Prevention Device) and a QCC1 or Type 1 (CGA810) tank connection. The tank connection must be compatible with the grill connection.**

## CANADIAN LP TANK REQUIREMENTS

- The LP tank must be constructed and marked in accordance with the specifications for LP gas tanks, T.C.

*NOTE: Your retailer can help you match a replacement tank to your grill.*

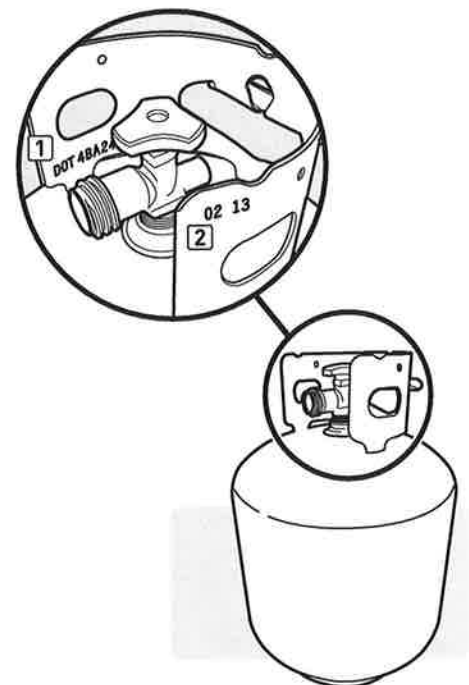

# IMPORTANT INFORMATION ABOUT LP GAS CONNECTIONS

## WHAT IS A REGULATOR?

Your Weber® gas grill is equipped with a pressure regulator, which is a device to control and maintain uniform gas pressure as gas is released from the LP tank.

## REGULATOR CONNECTIONS

Each Weber® LP regulator is designed for vapor withdrawal and is equipped with a UL-listed Type 1 tank connection as described in the latest edition of ANSI Z21.58. THE LP TANK THAT YOU CONNECT TO THE REGULATOR MUST BE EQUIPPED WITH A COMPATIBLE TYPE 1 CONNECTION IN THE TANK VALVE. This Type 1 connection allows you to make a fast and safe hookup between your Weber® gas grill and the LP tank.

*NOTE: Gas will not flow from the tank unless the Type 1 coupling is fully engaged.*

- The pressure regulator supplied with the Weber® gas grill must be used. This regulator is set for 11 inches of water column pressure.
- Replacement pressure regulator and hose assemblies must be those specified by Weber-Stephen Products LLC.
- Be sure the regulator is mounted with the small vent hole pointed downward so that it will not collect water. This vent should be free of dirt, grease, bugs, etc.
- The gas connections supplied with your Weber® gas appliance have been designed and tested to meet 100% of CSA and ANSI requirements.

**⚠ WARNING: Replacement LP tanks must match the regulator connection supplied with this Weber® gas appliance.**

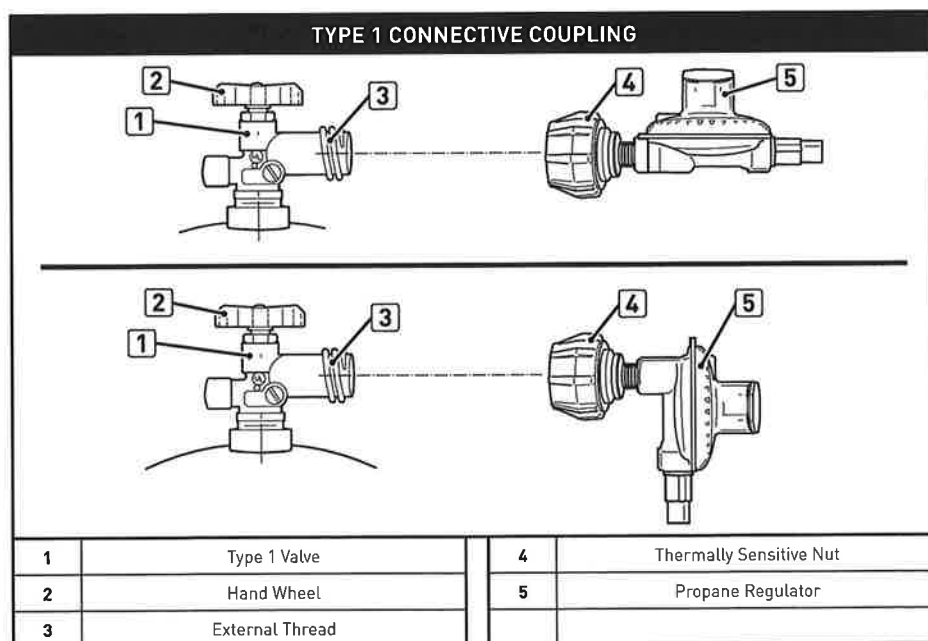

# LP TANK INSTALLATION AND REMOVAL

## FUELING YOUR GRILL

Before using your grill for the first time, you need to obtain an LP tank. New tanks can be purchased full; empty tanks can be refilled or exchanged. You may choose to purchase a spare LP tank so that you don't run out of fuel in the middle of cooking a meal.

⚠ **WARNING:** Never store an extra (spare) LP tank under or near the Weber® gas grill.

## INSTALLING THE LP TANK

LP tanks can vary based on the shape of the top collar assembly (the metal protective ring around the tank valve). Its shape determines how a tank will hang on the tank scale. One type of tank mounts with the valve facing forward (1). The other type mounts with the valve facing away from the fuel scale (2). To properly install your LP tank, first identify what type of tank you purchased. Weber recommends LP tanks with a 47.6 lb water capacity. Other tanks may be acceptable for use provided they are compatible with the appliance retention means (tank scale).

The LP tank is installed inside the base cabinet, on the tank scale (right side).

### Prepare Grill for Tank Installation

- A) Check that all burner control knobs are in the off (O) position. Your grill was shipped with control knobs in the off (O) position, but you should check to be sure that they are turned off. Check by pushing in and turning knobs clockwise. If they do not turn, they are off. If they do turn, continue turning them clockwise until they stop; then they are off. If your grill has a side burner, make sure the side burner control knob is turned off.
- B) Open base cabinet door.

### Install the LP Tank

- A) Loosen tank lock wing nut. Swing tank lock up (3).
- B) Turn the LP tank so the opening of the valve is either to the front or side of the Weber® gas grill.

⚠ **WARNING:** Make sure that the LP tank valve is closed. Close by turning valve clockwise.

- C) Lift tank up into position on the tank scale (4).
- D) Swing the tank lock down. Tighten the wing nut.

### Connect the Regulator / Hose to the Tank

- A) Remove the plastic dust cover from the tank valve.
- B) Screw the regulator coupling onto the tank valve, turning clockwise, or to the right (5). **Hand-tighten only.**

*NOTE: This connection tightens clockwise and will not allow gas to flow unless the connection is tight.*

⚠ **WARNING:** Do not use a wrench to tighten the connection. Using a wrench could damage the regulator coupling and could cause a leak.

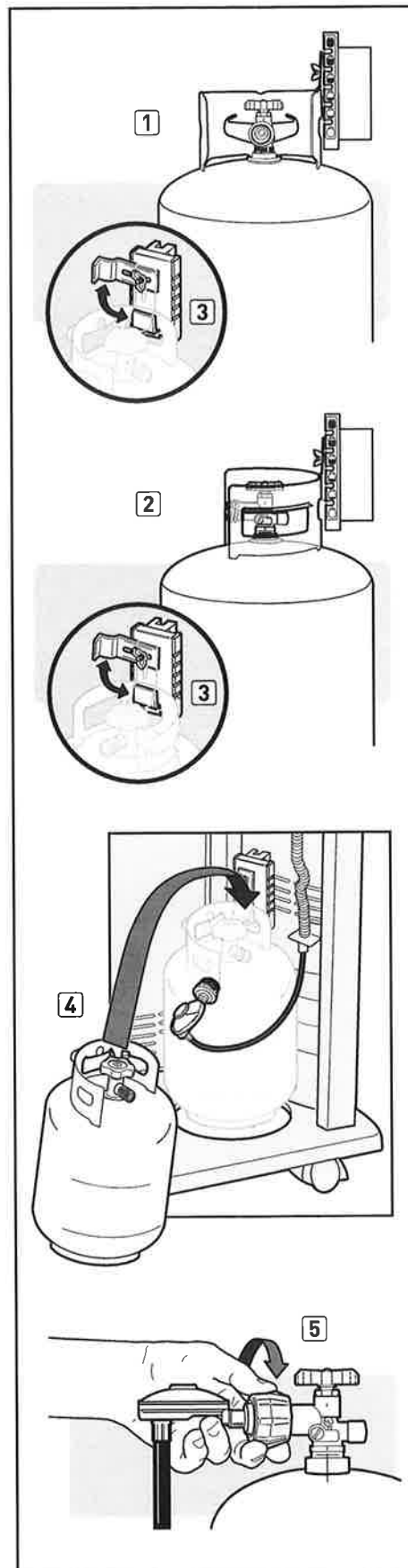

## LP TANK INSTALLATION AND REMOVAL

### FUEL LEVEL

The tank scale, a feature on some of our grills, will indicate the propane supply so you can refill the tank before running out of fuel. Check the fuel level by viewing the orange level indicator line, located on the side of the tank scale. When the indicator line is at the bottom, the tank is empty (1). When it is in the middle, the tank is half full (2). When it is at the top, the tank is full (3).

### REMOVING THE LIQUID PROPANE TANK FOR REFILLING OR REPLACEMENT

A full LP tank will last about 18–20 hours of cooking time at normal use. You do not have to run out of fuel before you can refill the tank. In fact, we recommend that you refill the LP tank before it is completely empty.

#### Removal of the LP Tank

- A) Close tank valve (turn clockwise) (4).
- B) Unscrew regulator coupling by turning counterclockwise, by hand only (5).
- C) Loosen tank lock wing nut and turn tank lock up out of the way (6).
- D) Lift tank off tank scale.

### FILLING THE LP GAS TANK

Proper filling of your tank is done by weight or volume, as described in NFPA 58. Please make sure your filling station uses one of these two methods, and ask your filling station to read the purging and filling instructions on the LP tank before attempting to fill it.

#### ⚠ DANGER

**NEVER** store a spare LP tank under or near Weber® gas appliances. **NEVER** fill the tank beyond 80% full. Failure to follow these statements exactly may result in a fire causing death or serious injury.

⚠ **WARNING:** We recommend that your LP tank be filled at an authorized LP gas dealer, by a qualified attendant, who fills the tank by weight. **IMPROPER FILLING IS DANGEROUS.**

*NOTE:* Be certain tank is purged of trapped air prior to first filling. Your LP dealer is equipped to do this.

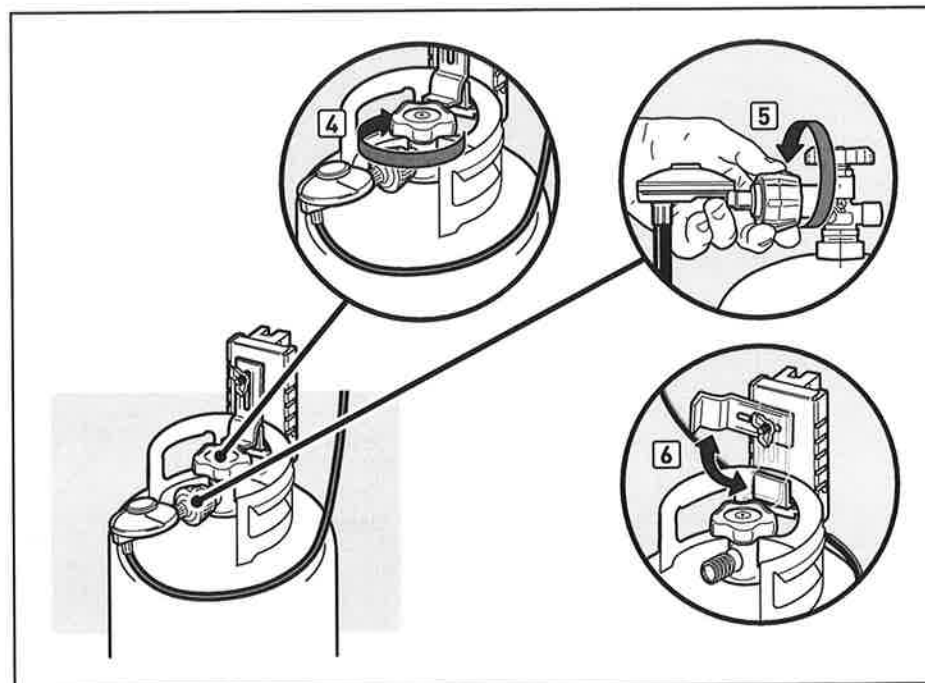
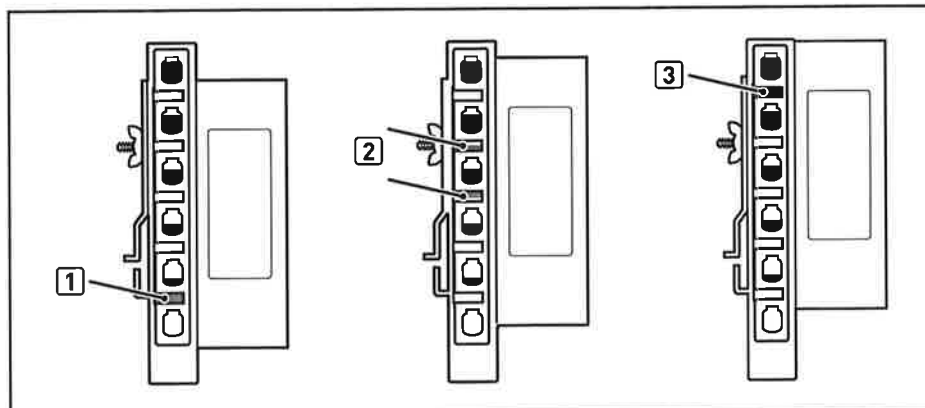

# PREPARING TO USE YOUR GRILL

## WHAT IS A LEAK CHECK?

The fuel system in your grill features connections and fittings. A leak check is a reliable way to make sure that no gas is escaping from any of the connections or fittings.

Although all factory-made connections have been thoroughly checked for gas leaks, it's important to perform a leak check before using your grill for the first time, as well as anytime you disconnect and reconnect a fitting and each time you perform routine maintenance.

## PARTIAL DISASSEMBLY OF YOUR GRILL FOR A LEAK CHECK

In order to do the leak check, you need to have access to the gas valves, which will require some simple grill disassembly.

### Confirm that Grill Is Off

- A) Turn gas supply off at source.
- B) Check that **ALL** burner control knobs are in the off (O) position (1). Control knobs are shipped in the off (O) position, but you should check to be sure that they are turned off. Check by pushing control knobs in and turning them clockwise. If they do not turn, they are off. If they do turn, continue turning them clockwise until they stop; then they are off. If your grill has a side burner, make sure the side burner control knob is turned off.

### Remove Control Panel

You will need: A Phillips screwdriver.

- A) Disconnect the two wires from the igniter button located on the underside of the control panel (2).  
*NOTE: Pull from terminals at ends of wires.*
- B) Remove control knobs (3).
- C) Remove the screws from the front of the control panel with a Phillips screwdriver (4).
- D) Carefully lift control panel up and then pull forward away from frame (5).

Your grill is now ready for a leak check. Proceed to "CHECKING FOR GAS LEAKS."

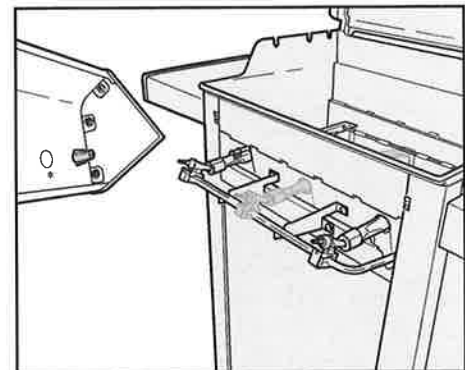
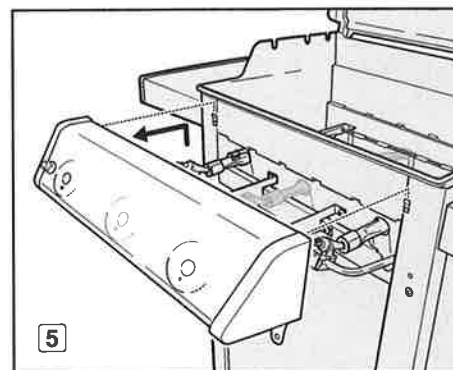
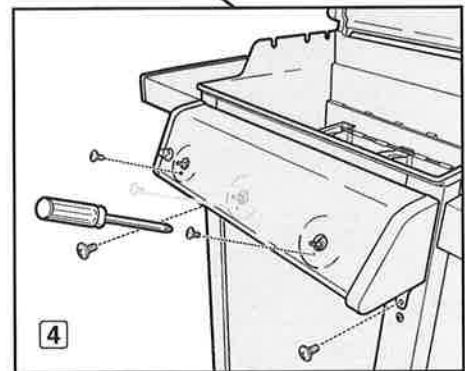
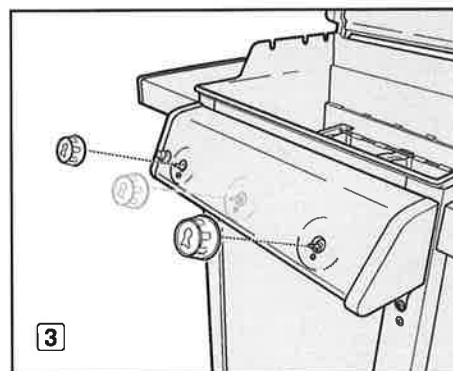
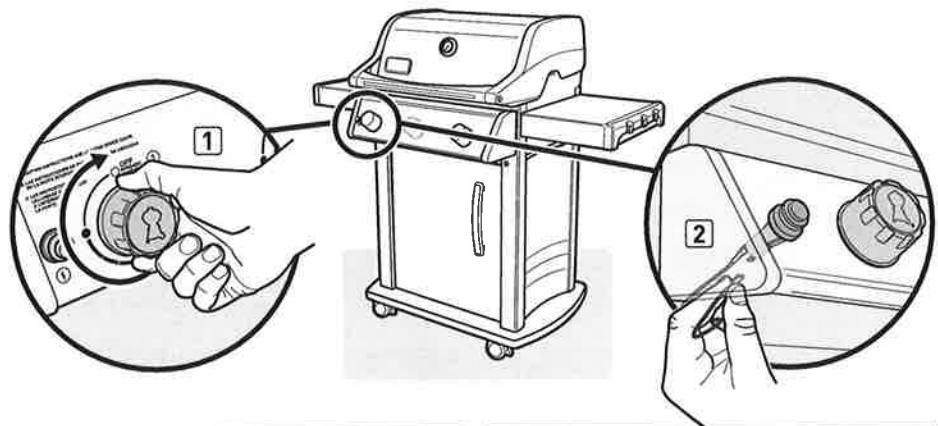

# PREPARING TO USE YOUR GRILL

## ⚠ DANGER

Do not use an open flame to check for gas leaks. Be sure there are no sparks or open flames in the area while you check for leaks. Sparks or open flames will result in a fire or explosion, which can cause serious bodily injury or death and damage to property.

⚠ **WARNING:** The gas connections of your gas grill have been factory tested. We do, however, recommend that you leak check all gas connections before operating your gas grill.

⚠ **WARNING:** Perform these leak checks even if your grill was dealer or store assembled.

⚠ **WARNING:** You should check for gas leaks every time you disconnect and reconnect a gas fitting.

*NOTE: All factory-made connections have been thoroughly checked for gas leaks and the burners have been flame-tested. As a safety precaution, however, you should check all fittings for leaks before using your Weber® gas grill. Shipping and handling may loosen or damage a gas fitting.*

## CHECKING FOR GAS LEAKS

You will need: A spray bottle or brush or rag and a soap and water solution. (You can make your own soap and water solution by mixing 20% liquid soap with 80% water; or, you can purchase leak check solution in the plumbing section of any hardware store.)

A) Turn gas supply on at source (1).

⚠ **WARNING:** Do not ignite burners when leak checking.

B) To check for leaks, wet fittings with the soap and water solution, using a spray bottle, brush or rag. If bubbles form, or if a bubble grows, there is a leak. Apply the soap and water solution to the following connections:

- a) Regulator hose-to-bulkhead connection (2).
- b) Corrugated manifold hose-to-bulkhead connection (3).
- c) Corrugated manifold hose-to-manifold connection (4).

⚠ **WARNING:** If there is a leak at connections (2, 3 or 4), turn off the gas, tighten the fitting with a wrench, and recheck for leaks with soap and water solution. If a leak persists after tightening the fitting, turn off the gas. DO NOT OPERATE THE GRILL. Contact the Customer Service Representative in your area using the contact information on our web site.

Log onto [www.weber.com](http://www.weber.com).

- d) Regulator-to-tank connection (5).
- e) Regulator hose-to-regulator connection (6).
- f) Valves-to-manifold connections (7).

⚠ **WARNING:** If there is a leak at connections (5, 6, or 7), turn off the gas. DO NOT OPERATE THE GRILL. Contact the Customer Service Representative in your area using the contact information on our web site.

Log onto [www.weber.com](http://www.weber.com).

C) When leak checking is complete, turn gas supply off at the source and rinse connections with water.

*NOTE: Since some leak test solutions, including soap and water, may be slightly corrosive, all connections should be rinsed with water after checking for leaks.*

## Reinstall Control Panel

You will need: A Phillips screwdriver.

- A) Align valve stems with holes in control panel. Position top edge of control panel on tabs of frame assembly. Push control panel down into position.
- B) Fasten control panel with screws.
- C) Place control knobs onto valve stems.
- D) Connect the wires to the igniter button.

⚠ **WARNING:** Make sure that all parts are assembled and hardware is fully tightened before operating the grill. Your actions, if you fail to follow this product warning, may cause a fire, an explosion, or structural failure resulting in serious personal injury or death as well as damage to property.

Now you are ready to use your grill.

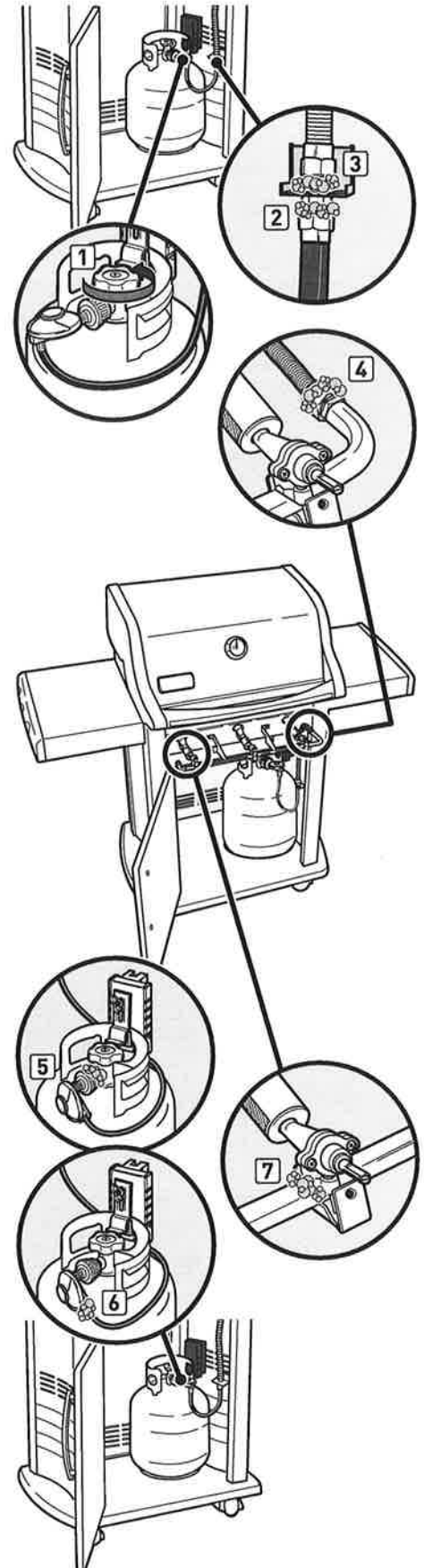

### TIPS & HINTS

- Always preheat the grill before cooking. Set all burners on high heat and close lid; preheat for 10 to 15 minutes, or until thermometer registers 500° – 550°F (260° – 290°C).
- The temperature of your gas grill may run hotter than normal for the first few uses.
- Recipe grilling times are based on outside temperatures of 70°F (20°C) and little or no wind. Allow for more cooking time on cold or windy days, or at higher altitudes. Allow for less cooking time in extremely hot weather.
- Grilling conditions may require adjustment of the burner controls to attain the correct cooking temperatures.
- Sear meats and cook with the lid down for perfectly grilled food every time.
- Crowding food onto a cooking grate means more time will be required to cook the food.
- Trim excess fat from steaks, chops, and roasts, leaving no more than a scant ¼ inch (6.4 mm) of fat. Less fat makes cleanup easier, and is a virtual guarantee against unwanted flare-ups.
- In general, large pieces of meat will require more cooking time per pound than small pieces of meat.
- Some foods, such as a casserole or thin fish fillets, will require a container for grilling. Disposable foil pans are very convenient, but any metal pan with ovenproof handles can also be used.
- Foods in containers, such as baked beans, will require more time if grilled in a deep casserole than in a shallow baking pan.
- Foods placed on the cooking grate directly above burners may require turning or moving to a less hot area.
- Use tongs rather than a fork for turning and handling meats to avoid losing natural juices. Use two spatulas for handling large whole fish.
- Always be sure the slide-out grease tray and catch pan are clean and free from debris.
- Do not line the slide-out grease tray with foil. This could prevent the grease from flowing into the catch pan.
- If an unwanted flare-up should occur, turn all burners off and move food to another area of the cooking grate. Any flames will quickly subside. After flames subside, relight the grill. **NEVER USE WATER TO EXTINGUISH FLAMES ON A GAS GRILL.**
- Using a timer will help to alert you when “well done” is about to become “overdone.”

### PREHEATING

Preheating the grill before grilling is important. To preheat: Light your grill according to the instructions in the Owner's Guide; then turn all burners to start/high (H) position, close the lid, and preheat until the temperature reaches between 500° and 550°F (260° and 290°C), the recommended broiling temperature. This will take 10 to 15 minutes depending on conditions such as air temperature and wind. After preheating, you can adjust the individual burners as desired.

**⚠ WARNING: Should the burners go out while grill is in operation, turn all gas valves off. Open the lid and wait five minutes before attempting to relight grill, using the igniting instructions.**

### COVERED COOKING

All grilling is done with the lid down to provide uniform, evenly circulated heat. With the lid closed, the gas grill cooks much like a convection oven. The thermometer in the lid indicates the cooking temperature inside the grill. All preheating and grilling is done with the lid down. No peeking — heat is lost every time you lift the lid.

### FLAVORIZER® SYSTEM

The closed lid and Flavorizer® bars produce that “outdoor” flavor in the food. When meat juices drip from the food onto the specially angled Flavorizer® bars, they create smoke that gives foods an irresistible grilled flavor. Thanks to the unique design of the burners, the Flavorizer® bars, and the flexible temperature controls, uncontrolled flare-ups are virtually eliminated, because YOU control the flames.

### DRIPPINGS AND GREASE

Because of the special design of the Flavorizer® bars and burners, excess fats are directed down the slide-out grease tray and into the catch pan. Disposable drip pans that fit the catch pan are available.

## SAFETY CHECKS BEFORE USING YOUR GRILL

### SAFETY FIRST

It's a good idea to get in the habit of performing a few safety checks before grilling.

Safety must be considered when you are deciding where to place and operate your grill. Be sure to read the following warnings before installing or using your grill.

#### WARNINGS:

- ⚠ Only use this grill outdoors in a well-ventilated area. Do not use in a garage, building, breezeway or any other enclosed area.
- ⚠ Your Weber® gas grill shall not be used beneath overhead combustible construction.
- ⚠ Your Weber® gas grill is not intended to be installed in or on recreational vehicles and/or boats.
- ⚠ Do not use the grill within 24 inches of combustible materials. This includes the top, bottom, back or sides of the grill.
- ⚠ Keep the cooking area clear of flammable vapors and liquids such as gasoline, alcohol, etc., and combustible materials.
- ⚠ Keep ventilation openings for tank enclosure free and clear from debris.
- ⚠ The entire cookbox gets hot when in use. Do not touch.
- ⚠ Do not move the Weber® gas grill when operating or while grill is hot.

When you are getting ready to grill, your first thought should always be safety. Following are a few safety checks that you should perform each time you grill.

#### SLIDE-OUT GREASE TRAY

Your grill was built with a grease collection system, which funnels grease away from food and into removable containers.

Check the slide-out grease tray for grease build-up each time you use your grill. Remove excess grease with a plastic scraper (1). Wash the grease tray with a soap and water solution and rinse with water.

⚠ **CAUTION:** Do not line the slide-out grease tray with aluminum foil.

#### CATCH PAN AND DISPOSABLE DRIP PAN

Grease from the slide-out grease tray funnels into a catch pan. Cleaning the catch pan is just as important as cleaning the slide-out grease tray.

Check the catch pan for grease build-up each time you use your grill. Remove excess grease with a plastic scraper (2). Wash the catch pan with warm, soapy water and rinse with water. To keep the catch pan cleaner longer, you can line the catch pan with a Weber® disposable drip pan or with aluminum foil.

⚠ **WARNING:** Check the slide-out grease tray and catch pan for grease build-up before each use. Remove excess grease to avoid a grease fire. A grease fire can cause serious bodily injury or damage to property.

#### HOSE INSPECTION

The hose should be inspected routinely for any signs of cracking (3).

⚠ **WARNING:** Check hose before each use of grill for nicks, cracking, abrasions or cuts. If the hose is found to be damaged in any way, do not use the grill. Replace using only Weber® authorized replacement hose. Contact the Customer Service Representative in your area using the contact information on our web site. Log onto [www.weber.com](http://www.weber.com).

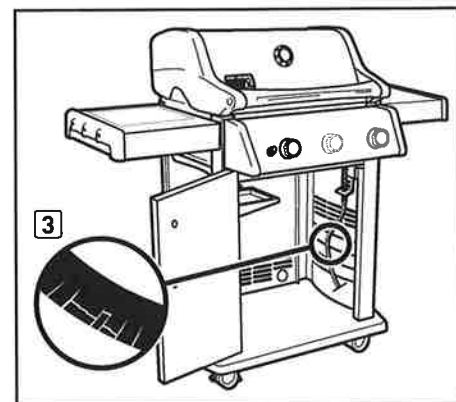
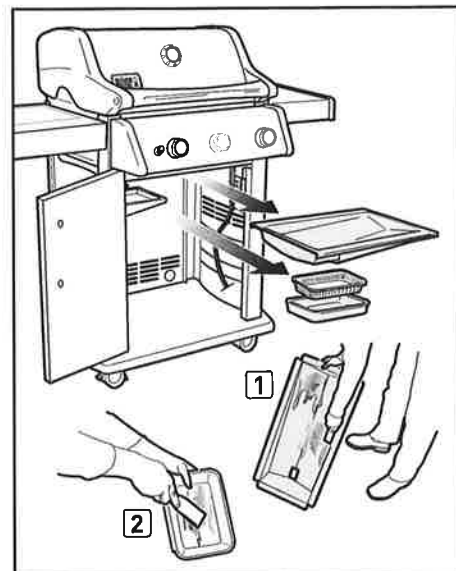

# MAIN BURNER IGNITION & USAGE

## METHODS OF BURNER IGNITION

There are two ways to ignite burner 1. The first is by using the electronic Crossover® ignition system built into your grill. The second is with a match.

Next are the steps for igniting your grill using the electronic Crossover® ignition system. On the following page are steps for igniting your grill with a match.

Summary lighting instructions are inside the cabinet door.

## MAIN BURNER IGNITION

### Electronic Crossover® Ignition System

The electronic Crossover® ignition system ignites burner 1 with a spark from the igniter electrode inside the Gas Catcher™ ignition chamber. You generate the energy for the spark by pushing the igniter button. You will hear the igniter clicking. Burner(s) 2 (and 3) can be lit after burner 1 is lit.

A) Open the grill lid (1).

### ⚠ DANGER

**Failure to open the lid before igniting the grill's burners, or not waiting five minutes to allow the gas to clear if the grill does not light, may result in an explosive flare-up which can cause serious bodily injury or death.**

B) Make sure ALL burner control knobs are turned off (2). Check by pushing control knobs in and turning them clockwise until they stop.

⚠ **WARNING:** The burner control knobs must be in the off (O) position before you turn on the LP tank valve. If they are not in the off (O) position when you turn on the LP tank valve, the "excess gas flow control" feature will activate, limiting the flow of gas from the LP tank. If this should occur, turn off the LP tank valve and burner control knobs. Start over.

### ⚠ DANGER

**When the "excess gas flow control" feature is activated, a small amount of gas is still flowing to the burners. After turning off the LP tank valve and burner control knobs, wait at least five minutes for the gas to clear before attempting to light the grill. Failure to do so may result in an explosive flare-up, which can cause serious bodily injury or death.**

C) Turn the LP tank on by slowly turning the tank valve counterclockwise; wait 60 seconds (3).

D) Push burner 1 control knob in and turn it counterclockwise to start/high (H) position (4).  
**IMPORTANT:** Always ignite burner 1 first. The other burner(s) ignite from burner 1.

E) Push and hold in the igniter button (5). You will hear the igniter clicking.

F) Check that burner 1 is lit by looking through the cooking grates. You should see a flame.

⚠ **WARNING:** While igniting the grill or cooking, never lean over open grill.

⚠ **WARNING:** If burner 1 fails to ignite within five seconds, stop, turn the burner control knob to off and wait five minutes to allow the gas to clear before you try again or light with a match.

G) After burner 1 is lit, you can turn on burner 2 (and burner 3).

## TO EXTINGUISH BURNER

Push each burner control knob in and turn it clockwise to the off (O) position. Turn gas supply off at the source.

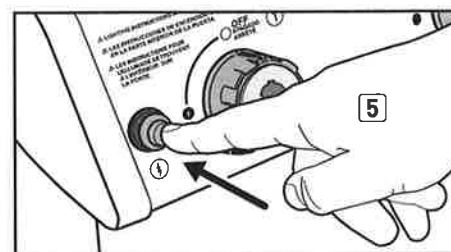
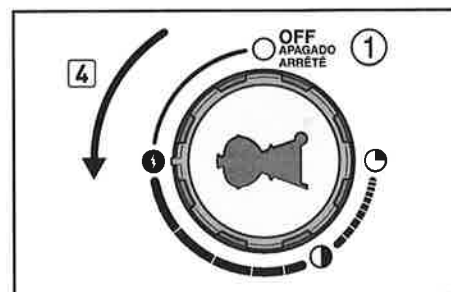
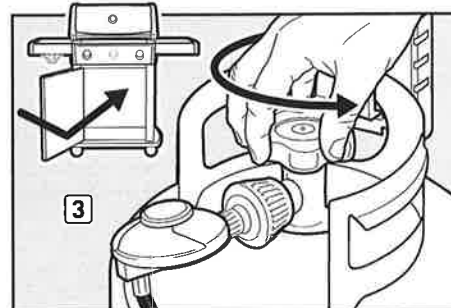
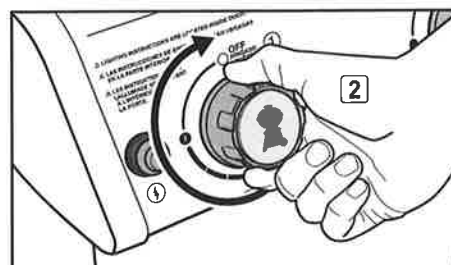
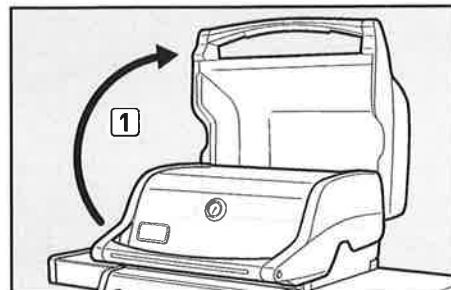

**Some batteries have a plastic protective wrap around them. This plastic must be removed before you attempt to ignite your grill. Do not confuse this plastic with the battery label.**

## MAIN BURNER IGNITION & USAGE

### MAIN BURNER IGNITION

#### Lighting with a Match

- A) Open the grill lid (1).

#### **⚠ DANGER**

Failure to open the lid before igniting the grill's burners, or not waiting five minutes to allow the gas to clear if the grill does not light, may result in an explosive flare-up which can cause serious bodily injury or death.

- B) Make sure ALL burner control knobs are turned off (2). Check by pushing control knobs in and turning them clockwise until they stop.

**⚠ WARNING:** The burner control knobs must be in the off (O) position before you turn on the LP tank valve. If they are not in the off (O) position when you turn on the LP tank valve, the "excess gas flow control" feature will activate, limiting the flow of gas from the LP tank. If this should occur, turn off the LP tank valve and burner control knobs. Start over.

#### **⚠ DANGER**

When the "excess gas flow control" feature is activated, a small amount of gas is still flowing to the burners. After turning off the LP tank valve and burner control knobs, wait at least five minutes for the gas to clear before attempting to light the grill. Failure to do so may result in an explosive flare-up, which can cause serious bodily injury or death.

- C) Turn the LP tank on by slowly turning the tank valve counterclockwise; wait 60 seconds (3).  
D) Put match in the matchstick holder and strike match. Insert matchstick holder with lit match down through the cooking grates, past the Flavorizer® bars and next to burner 1 (4).  
E) Push burner 1 control knob in and turn it counterclockwise to start/high (H) position (5). **IMPORTANT: Always ignite burner 1 first. The other burner(s) ignite from burner 1.**  
F) Check that burner 1 is lit by looking through the cooking grates. You should see a flame.

**⚠ WARNING:** While igniting the grill or cooking, never lean over open grill.  
**⚠ WARNING:** If burner 1 fails to ignite within five seconds, stop, turn the burner control knob to off and wait five minutes to allow the gas to clear before you try again.

- G) After burner 1 is lit, you can turn on burner 2 (and burner 3).

### TO EXTINGUISH BURNER

Push each burner control knob in and turn it clockwise to the off (O) position. Turn gas supply off at the source.

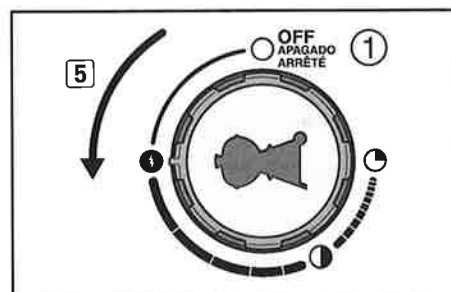
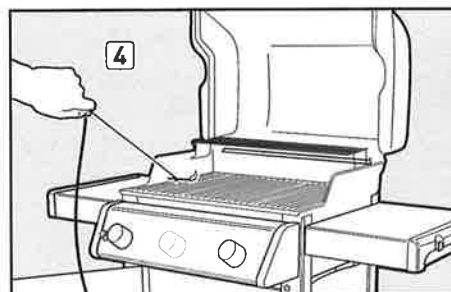
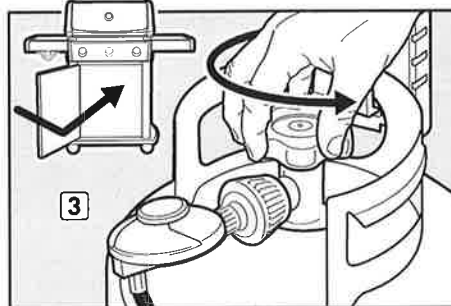
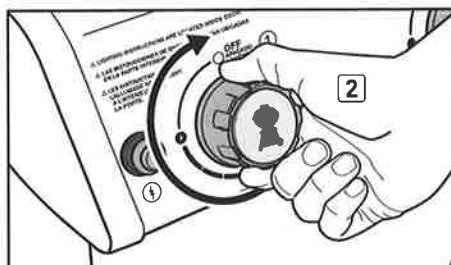
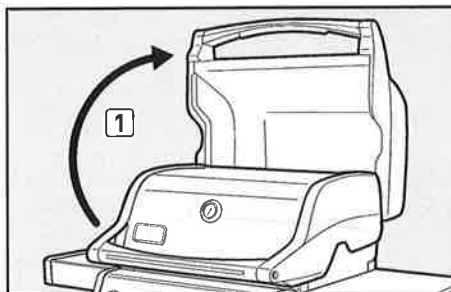

# TROUBLESHOOTING

## GENERAL TROUBLESHOOTING

### PROBLEMS

**Burners do not ignite.**

**Burners have a small flickering flame when burner control knobs are in the high (H) position.**

**Grill temperature only reaches 250° to 300° F in the high (H) position.**

**Burner does not ignite when you push the igniter button.**

**Burner does not ignite, or flame is low in high (H) position.**

**Burner flame pattern is erratic.**

**Flame is low when burner is on high (H) position.**

**Flames do not run the whole length of the burner tube.**

**Burners burn with a yellow or orange flame, in conjunction with the smell of gas.**

**Experiencing flare-ups.**

**⚠ CAUTION: Do not line the slide-out grease tray with aluminum foil.**

**Inside of lid appears to be "peeling."  
(Resembles paint peeling.)**

### SOLUTIONS

The excess gas flow safety device, which is part of the grill-to-tank connection, may have been activated. To reset the excess gas flow safety device, refer to "MAIN BURNER IGNITION."

**⚠ DANGER:** When the "excess gas flow control" feature is activated, a small amount of gas is still flowing to the burners. After turning off the LP tank valve and burner control knobs, wait at least five minutes for the gas to clear before attempting to light the grill. Failure to do so may result in an explosive flare-up, which can cause serious bodily injury or death.

Be sure that there is gas flow to the burners by attempting to match light your burners. Refer to "MAIN BURNER IGNITION—Lighting with a Match." If match lighting is successful, the problem lies in the ignition system. Refer to "MAINTAINING THE ELECTRONIC CROSSOVER® IGNITION SYSTEM."

Be sure that wires are correctly inserted into terminals on igniter module. Check that the wires are connected to terminals on igniter button under the control panel. Refer to "IGNITER MODULE WIRE CHART."

If a new battery is installed, confirm that battery's plastic wrapping has been removed. Verify that the battery is in good condition and has been installed correctly. Refer to "MAINTAINING THE ELECTRONIC CROSSOVER® IGNITION SYSTEM."

LP fuel could be low or empty. Refill LP tank.

Fuel hose could be bent or kinked. Straighten fuel hose.

Clean burner ports that run down the entire length of burner tube. Refer to "CLEANING THE BURNER TUBE PORTS."

Inspect spider/insect screens for possible obstructions. Clean spider/insect screens. Refer to "CLEANING THE SPIDER/INSECT SCREENS."

Grill must be preheated with all burners on high for 10 to 15 minutes. Refer to "PREHEATING THE GRILL."

Clean the cooking grates, Flavorizer® bars and cookbox thoroughly to remove grease. Refer to "CLEANING FOR PERFORMANCE."

The slide-out grease tray may be dirty and is not allowing grease to flow into catch pan. Clean slide-out grease tray. Refer to "CLEANING THE GREASE MANAGEMENT SYSTEM."

The inside of the lid is porcelain enamel or stainless steel. It is not painted. It cannot "peel." What you are seeing is baked-on grease that has turned to carbon and is flaking off. **THIS IS NOT A DEFECT.** Clean thoroughly. Refer to "CLEANING THE LID."

If problems cannot be corrected by using these methods, please contact the Customer Service Representative in your area using the contact information on our web site. Log onto [www.weber.com](http://www.weber.com).

# CLEANING FOR GREAT MEALS

## MEAL-TO-MEAL MAINTENANCE

Cleaning your gas grill each time you grill out is an essential step that will keep your grill in top performance for years to come. Here we will guide you through the step-by-step instructions for cleaning your grill before each meal to ensure your food comes out perfect each time. For a deeper clean, refer to the annual maintenance section.

The Meal-To-Meal Maintenance plan includes the following three simple, yet important steps that should be followed prior to every time you grill.

### MAINTAINING THE GREASE MANAGEMENT SYSTEM

The first step in our Meal-To-Meal Maintenance plan is to inspect the grease management system. Your grill was built with a grease management system which consists of an angled slide-out grease tray and catch pan. Grease is channeled down the slide-out grease tray and into the catch pan.

You will need: A plastic scraper.

- A) Confirm that grill is off and cool.
- B) Remove the slide-out grease tray by easily pulling the tray out of the cabinet. Remove excess grease with a plastic scraper (1).

**⚠ CAUTION: Do not line the slide-out grease tray with aluminum foil.**

- C) Remove the catch pan. Lift the disposable drip pan out of the catch pan (2). Check for excessive amount of grease. Discard disposable drip pan when necessary and replace with a new one.

**⚠ WARNING: Check the slide-out grease tray and catch pan for grease build-up before each use. Remove excess grease to avoid a grease fire. A grease fire can cause serious bodily injury or damage to property.**

### PREHEATING THE GRILL

Preheating your grill is the second step. The heat burns off or loosens the bits and pieces of the previous meal.

- A) Open the grill lid (3).
- B) Light your grill according to the ignition instructions in this guide or on the inside door or side table of your gas grill.
- C) Close lid.
- D) Turn all burners to start/high for 10 to 15 minutes or until thermometer registers 500° - 550°F (260° - 290°C) to preheat the grill (4).
- E) Once grill is preheated, continue with cleaning the cooking grate as described next.

**⚠ WARNING: Use heat-resistant barbecue mitts or gloves when operating grill.**

### CLEANING THE COOKING GRATE

Finally, the last step is to brush the debris off the hot cooking grate(s).

You will need: A stainless steel bristle grill brush.

- A) Immediately after preheating, brush the grates with a stainless steel bristle grill brush (5). This step is not only for cleanliness. It also prevents food from sticking.

**⚠ CAUTION: Grill brushes should be checked for loose bristles and excessive wear on a regular basis. Replace brush if any loose bristles are found on cooking grates or brush. Weber recommends purchasing a new stainless steel bristle grill brush at the beginning of every spring.**

If you notice that your grill has hot or cold spots, or the flames are not burning blue, you will need to perform a more thorough cleaning of the burner tubes. Refer to "CLEANING FOR SAFETY" section for more details.

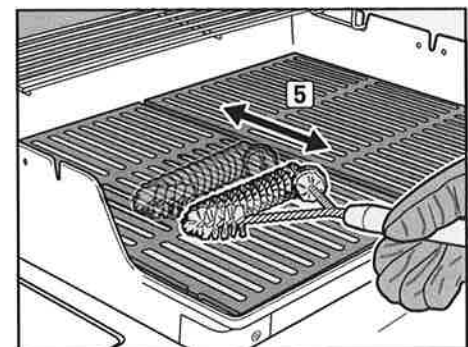
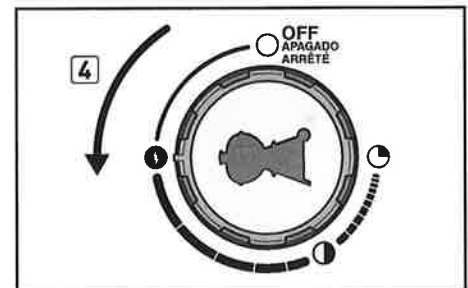
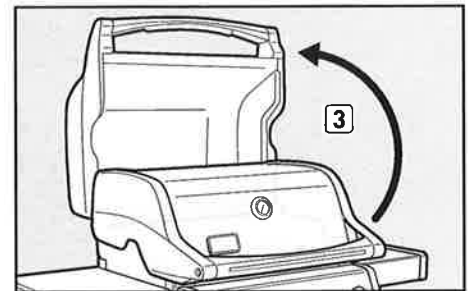
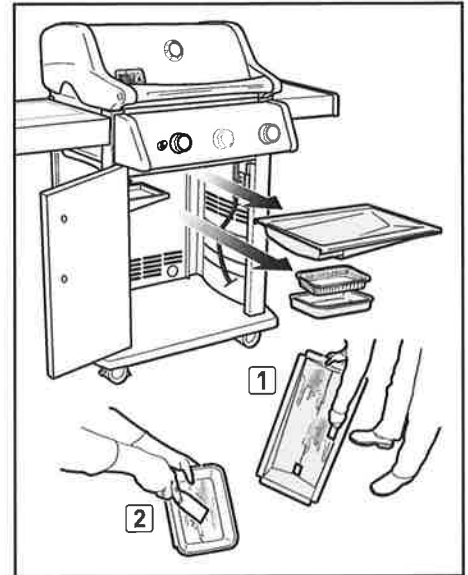

## CLEANING FOR SAFETY

### CLEANING THE BURNER TUBES

Over time, with repeated use, your grill may show symptoms that it needs a more thorough cleaning. Some of these symptoms are:

- Grill does not reach desired temperature
- Grill heats unevenly
- One or more of burners fail to ignite
- Smell of gas and improper flame pattern

These symptoms arise because the burner tubes need extra care. It is essential to clean the burner tubes to keep your grill performing as safely and efficiently as on day one.

#### **⚠ DANGER**

**Failure to correct any problems described on this page may result in a fire, which can cause serious bodily injury or death, and cause damage to property.**

Two areas on the burner tubes that are key to optimum performance are the ports (small openings running along the length of the burner tubes) and the spider/insect screens on the ends of the burner tubes. Keeping these areas clean is essential for safe operation.

The burner tubes in your Weber grill were factory set for the correct air and gas mixture. When the burner tubes are performing correctly, you will see a specific flame pattern. The tips may occasionally flicker yellow (1), with a descending light blue (2) to dark blue flame (3). If the flames do not match the above flame pattern description, it could be an indication that the burner ports and/or spider/insect screens need cleaning.

Below is important information about the maintenance of these two key components of the burner tubes.

#### CLEAN THE BURNER TUBE PORTS

Over time, from repeated use of the grill, the burner tube ports (4) may become dirty and blocked. Blocked and dirty ports can restrict full gas flow. This obstruction could result in a fire (5) in and around the gas valves, causing serious damage to your grill.

Common symptoms of blocked or dirty ports may include:

- Grill does not reach desired temperature
- Grill heats unevenly
- One or more of the burners fail to ignite
- Gas is smelled in conjunction with some or all of the ports not lighting.

*Note: The above symptoms can also be a sign that the "excess gas flow control" feature has activated. Refer back to "MAIN BURNER IGNITION" to reset the excess flow safety device.*

You will need: A clean stainless steel bristle grill brush. Do not use a brush that has already been used to clean the cooking grates.

- A) Confirm that grill is off and cool.
- B) Remove cooking grates and Flavorizer® bars.
- C) Use the brush to clean the outside of the burner tubes and the Crossover® tube (6). Do not brush lengthwise along the tube, as this will only push debris from one hole to another. Note that the burner tubes will move slightly, as if they are loose, this is normal.
- D) When cleaning burner tube 1, avoid damaging the igniter electrode by carefully brushing around it (7).

**⚠ CAUTION: Do not enlarge the burner tube ports and do not use sharp objects to clear the ports individually.**

- E) Continue onto cleaning the spider/insect screens.

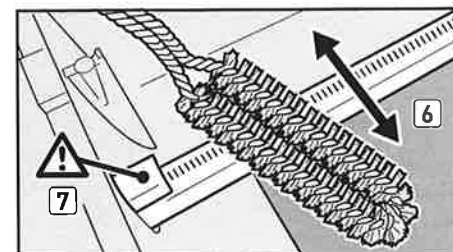
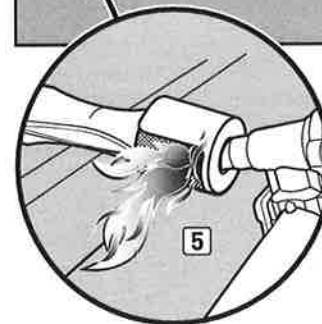
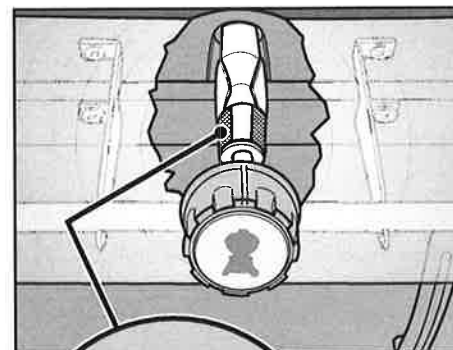
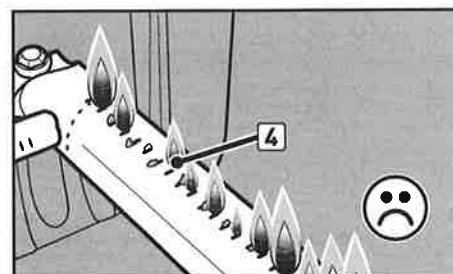
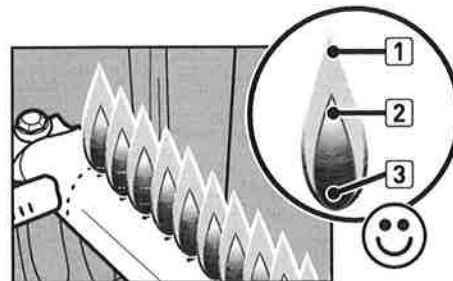

## CLEANING FOR SAFETY

### CLEAN THE SPIDER/INSECT SCREENS

The combustion air openings of the burner tubes (1) are fitted with stainless steel screens to help prevent spiders and other insects from spinning webs and building nests inside the venturi (tapered) section (2) of the burner tubes. These nests can obstruct the normal gas flow, and can cause gas to flow back out of the combustion air openings (3). This obstruction could result in a fire (4) in and around the gas valves, causing serious damage to your grill. Additionally, dust and debris can accumulate on the outside of the spider/insect screen and obstruct the oxygen flow to the burner tube.

Symptoms of spider/insect screen obstruction include:

- Gas is smelled in conjunction with burner flames that appear yellow and lazy

You will need: A Phillips screwdriver, soft bristle brush (toothbrush).

- Disconnect the two wires from the igniter button located on the underside of the control panel (5). *NOTE: Pull from terminals at ends of wires.*
  - Remove control knobs (6).
  - Remove the screws from the front of the control panel with a Phillips screwdriver (7).
  - Carefully lift control panel up and then pull forward away from frame (8).
  - Check the spider/insect screens at the ends of the burner tubes and clean them using the soft bristle brush (9).
- F) Reinstall control panel by aligning valve stems with holes in control panel. Position top edge of control panel on tabs of frame assembly. Push control panel down into position.
- G) Fasten control panel with screws.
- H) Place control knobs onto valve stems.
- I) Connect the wires to the igniter button.

- ⚠ **WARNING: Make sure that all parts are assembled and hardware is fully tightened before operating the grill. Your actions, if you fail to follow this product warning, may cause a fire, an explosion, or structural failure resulting in serious personal injury or death as well as damage to property.**

### CALL CUSTOMER SERVICE

If you are still experiencing any symptoms after cleaning the burner ports and spider screens, contact the Customer Service Representative in your area using the contact information on our web site. Log onto [www.weber.com](http://www.weber.com).

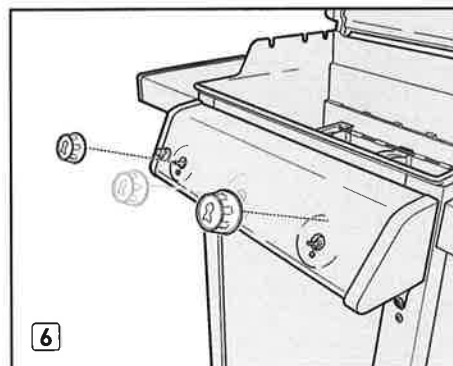
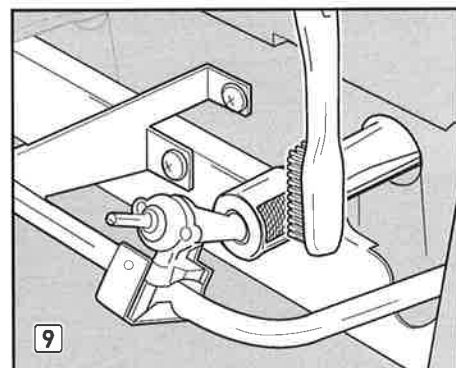
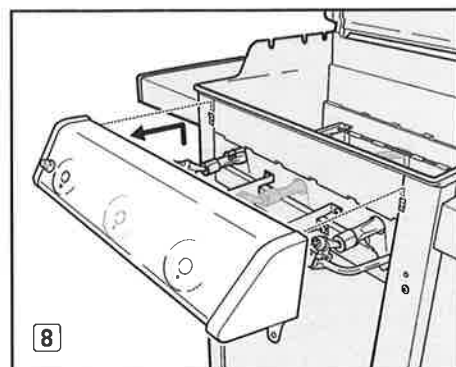
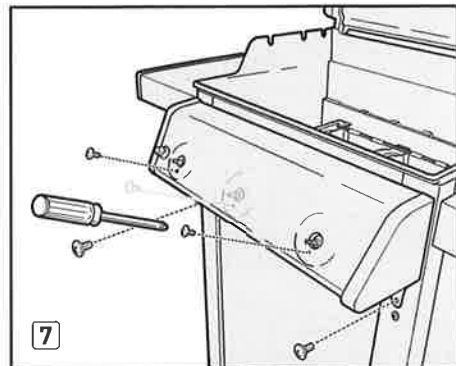
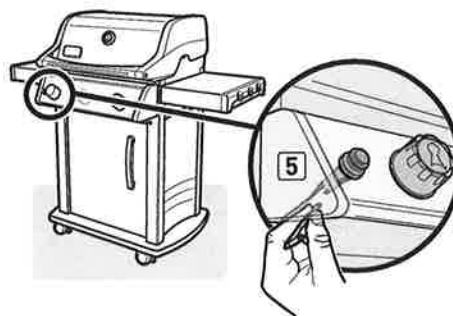
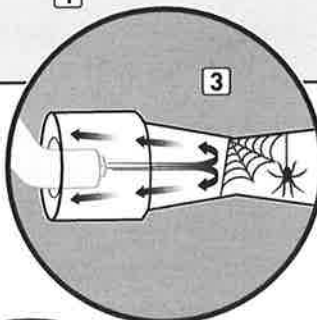
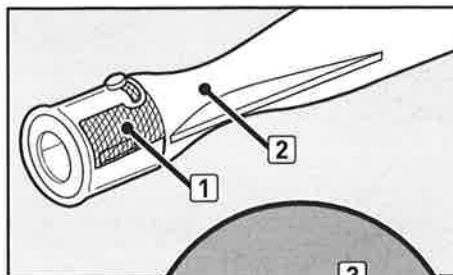

## CLEANING FOR PERFORMANCE

### PREVENTATIVE MAINTENANCE

Over time the performance of your grill can diminish if has not been maintained properly. Low temperatures, uneven heat, and food sticking to cooking grates are all possible side effects of poor grill cleaning and maintenance. Cleaning from the top to the bottom of your grill will ensure you get all of the vital areas thoroughly cleaned each and every time.

Preventative Maintenance consists of cleaning several areas on the inside of your grill as well as the outside. When your grill is **off and cool**, start by cleaning the inside from the top down to keep your grill running at peak performance.

**⚠ WARNING: Turn your Weber® gas grill off and wait for it to cool before giving it a thorough cleaning.**

#### CLEANING THE LID

From time to time you may notice "paint-like" flakes on the inside of the lid. During use, grease and smoke vapors slowly change into carbon and deposit on the inside of your lid. This deposit will eventually peel, and looks very similar to paint. These deposits are non toxic, but the flakes could fall onto your food if you do not clean the lid regularly.

You will need: A stainless steel bristle grill brush, paper towel.

- A) Brush the carbonized grease from the inside of the lid with a stainless steel bristle grill brush (1). To minimize further build-up, the inside of the lid can be wiped with a paper towel after cooking while the grill is still warm (not hot).

#### CLEANING THE COOKING GRATES

If you have been cleaning your cooking grates as recommended in our Meal-To-Meal Maintenance plan, the debris on your grates should be minimal.

You will need: A stainless steel bristle grill brush.

- A) With grates installed, brush the debris off your cooking grate with a stainless steel bristle grill brush (2).

**⚠ CAUTION: Grill brushes should be checked for loose bristles and excessive wear on a regular basis. Replace brush if any loose bristles are found on cooking grates or brush. Weber recommends purchasing a new stainless steel bristle grill brush at the beginning of every spring.**

- B) Take the grates out. (Do not place them onto the grill side tables as they may scratch the paint or stainless steel.)

#### CLEANING THE FLAVORIZER® BARS

Angled just right, the Flavorizer® bars catch drippings that smoke and sizzle adding flavor to your food. Any drippings not vaporized by the Flavorizer® bars follow the slope of their angle and are funneled away from the burner tubes. Not only does this help prevent flare-ups inside your grill, but it also protects the burner tubes from getting clogged.

You will need: A plastic scraper, stainless steel bristle grill brush.

- A) Scrape the Flavorizer® bars with the plastic scraper (3).
- B) If necessary, brush the Flavorizer® bars with the stainless steel bristle grill brush.
- C) Remove Flavorizer® bars and set aside. (Do not place them onto grill side tables as they may scratch the paint or stainless steel.)

**⚠ CAUTION: Do not clean Flavorizer® bars or cooking grates in a sink, dishwasher or self-cleaning oven.**

**⚠ CAUTION: Over time the development of rough surfaces can occur on the Flavorizer® bars. Wearing gloves is recommended when handling.**

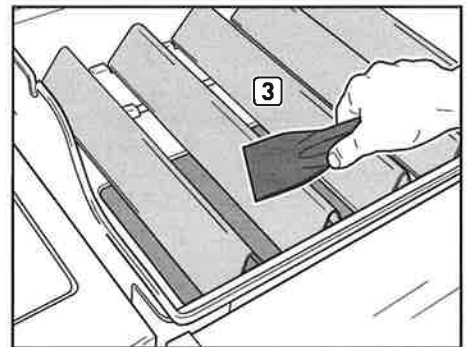
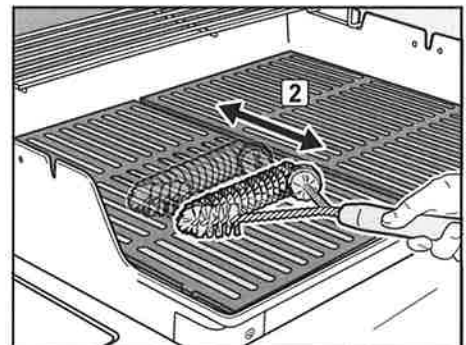
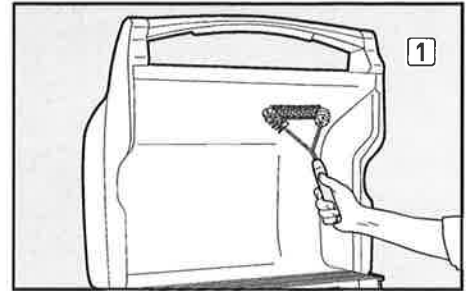

**To obtain replacement disposable drip pans, cooking grates and Flavorizer® bars, contact the local retailer in your area or log onto [www.weber.com](http://www.weber.com). If you need further assistance, contact your Customer Service Representative.**

## CLEANING FOR PERFORMANCE

### CLEANING THE BURNER TUBES

Keeping the burner tubes clean is essential for optimum performance. Refer to the previous pages for how to clean the burner tube ports and spider/insect screens.

### CLEANING THE COOKBOX

Look inside the cookbox for any grease accumulation or leftover food particles. Excessive accumulation can cause a fire.

You will need: A plastic scraper.

- A) Use plastic scraper to scrape debris off the sides and bottom of grill into the opening in bottom of cookbox (1). This opening leads debris into the slide-out grease tray.

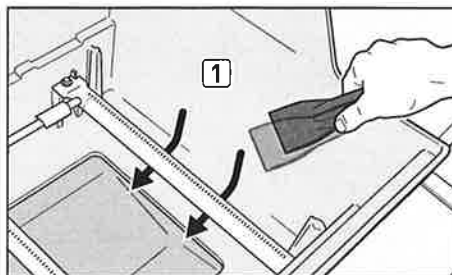

### CLEANING THE GREASE MANAGEMENT SYSTEM

Your grill was built with a grease management system, which consists of an angled slide-out grease tray and catch pan. Grease is channeled down the slide-out grease tray and into the catch pan.

You will need: A plastic scraper, paper towel.

- A) Remove the slide-out grease tray by easily pulling the tray out of the cabinet. Remove excess grease with a plastic scraper (2). If desired, wipe excess with paper towel.
- B) Remove the catch pan. Lift the disposable drip pan out of the catch pan, and discard (3). Replace with a new disposable drip pan.

**⚠ WARNING: Check the slide-out grease tray and catch pan for grease build-up before each use. Remove excess grease to avoid a grease fire. A grease fire can cause serious bodily injury or damage to property.**

**⚠ CAUTION: Do not line the slide-out grease tray with aluminum foil.**

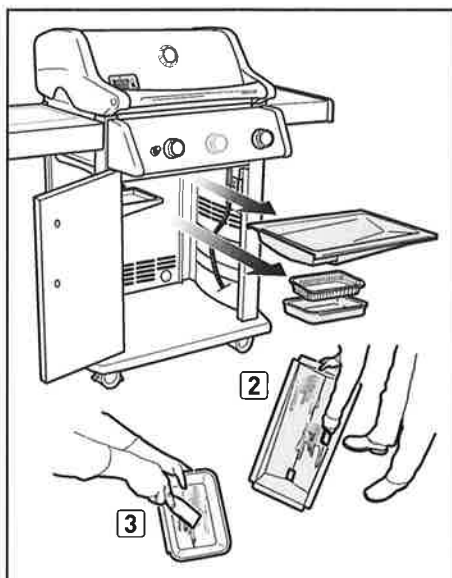

### CLEANING THE OUTSIDE OF THE GRILL

The outside of your grill may include stainless steel, porcelain-enameled, and plastic surfaces. Weber recommends the following methods based on the surface type.

#### Stainless Steel Surfaces

Clean stainless steel using a non-toxic, non-abrasive stainless steel cleaner or polish designed for use on outdoor products and grills. Do not risk scratching your stainless steel with abrasive pastes that do not clean or polish but change the color of the metal by removing the top chromium oxide film coating. Do not use paper towels.

You will need: A microfiber cloth, stainless steel cleaner.  
A) Spray cleaner onto stainless steel areas of grill. Using a microfiber cloth clean in the direction of the grain of the stainless steel.

#### Painted, Porcelain-Enameled Surfaces and Plastic Components

Clean painted, porcelain-enameled and plastic surfaces on the outside of your grill with warm soapy water.

You will need: Warm soapy water, paper towels or cloth.  
A) Wipe down the surfaces with warm soapy water. Rinse and dry thoroughly.

**⚠ IMPORTANT: Do not use any of the following to clean your grill: abrasive stainless steel polishes or paints, cleaners that contain acid, mineral spirits, or xylene, oven cleaner, abrasive cleansers (kitchen cleansers), and abrasive cleaning pads.**

### CLEANING THE OUTSIDE OF GRILLS THAT ARE IN UNIQUE ENVIRONMENTS

If your grill is subject to a particularly harsh environment, you will want to clean the outside more often. Acid rain, pool chemicals and salt water can cause surface rusting to appear. Wipe down the outside of your grill with warm soapy water. Follow up with a rinse and thorough drying. Additionally, you may want to apply a stainless steel cleaner weekly to prevent surface rust.

### STORAGE AND/OR NONUSE

For grills that have been stored or left unused for a while, it is important to follow these guidelines:

- The gas must be turned off at the LP tank when the Weber® gas grill is not in use.
- If storing the Weber® gas grill indoors, first DISCONNECT the gas supply and store the LP tank outdoors in a well-ventilated space.
- Do not store a disconnected LP tank in a building, garage, or any other enclosed area.
- If you do not disconnect the LP tank from the Weber® gas grill, be sure to keep both the grill and the tank outdoors in a well-ventilated area.
- The Weber® gas grill should be checked for gas leaks and any obstructions in the burner tubes before it is used. (Refer to "CLEANING FOR SAFETY.")
- Check that the areas under the control panel and the slide-out grease tray are free from debris that might obstruct the flow of combustion or ventilation air.
- The spider/insect screens should also be checked for any obstructions. (Refer to "CLEANING FOR SAFETY.")

# IGNITION SYSTEM MAINTENANCE

## MAINTAINING THE ELECTRONIC CROSSOVER® IGNITION SYSTEM

The igniter module supplies power to the electronic Crossover® ignition system and the side burner with one igniter button. Whether you are performing routine maintenance or a troubleshooting check on the ignition system, read the following to keep your ignition system working properly.

If the electronic Crossover® ignition system fails to ignite, you'll need to pinpoint where the problem is occurring: with the gas flow or with the electronic ignition system. Begin by attempting to match light your burners. Refer to "MAIN BURNER IGNITION - Lighting with a Match." If match lighting is successful, the problem lies in the ignition system.

- Verify that the AA battery (alkaline only) is in good condition and is installed correctly (1). Some batteries have a plastic protective wrap around them. This plastic must be removed before installing battery. Do not confuse this plastic with the battery label.
- Make sure the igniter wires are properly attached to the igniter module. Refer to the "IGNITER MODULE WIRE CHART" chart on this page.
- Make sure the ceramic igniter assembly is fully inserted into burner tube igniter channel (2). If properly positioned, you will hear a snap (3).
- Make sure the electronic igniter button is working by listening for clicking and looking for sparks at burner.

If the electronic Crossover® ignition system still fails to ignite, contact the Customer Service Representative in your area using the contact information on our web site. Log onto [www.weber.com](http://www.weber.com).

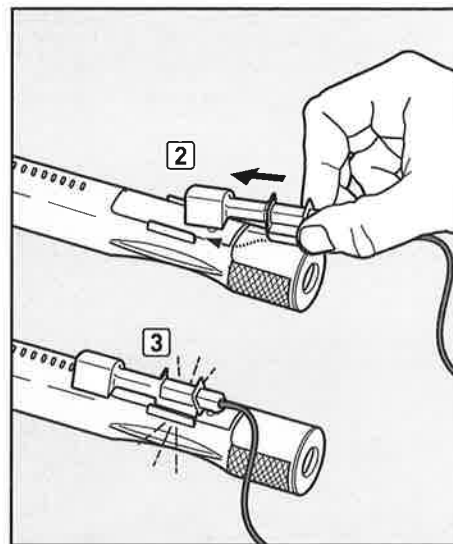
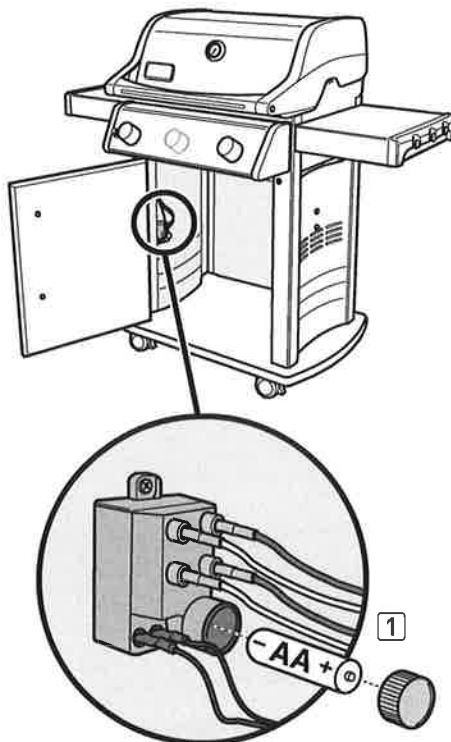

IGNITER MODULE WIRE CHART (E/S-210™ / E-310™ / SP-310™)

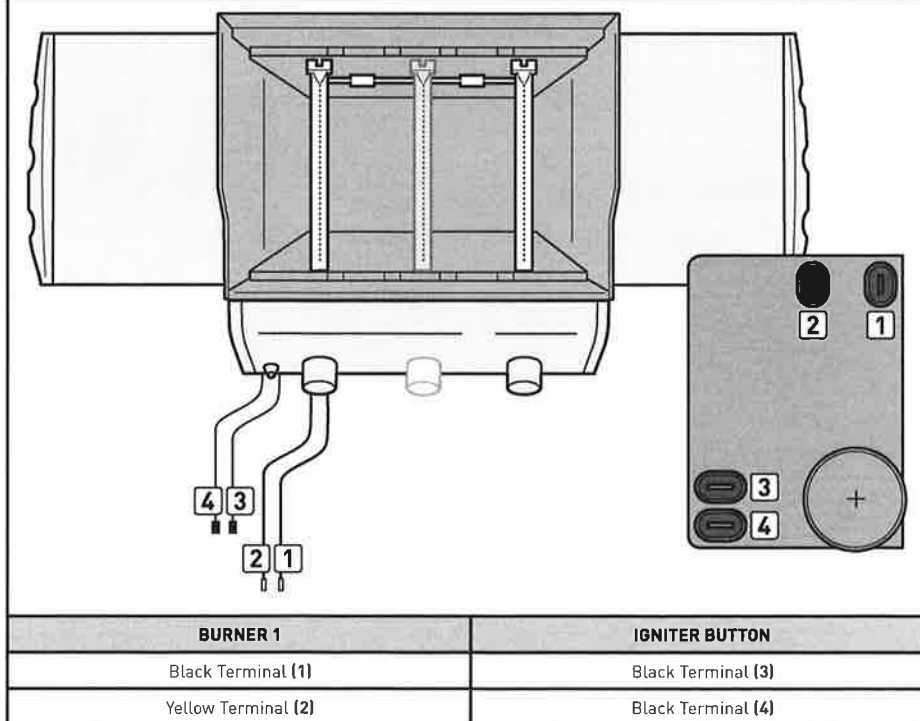

MEMO

**⚠ ATTENTION: This product has been safety tested and is only certified for use in a specific country. Refer to country designation located on outer carton.**

These parts may be gas carrying or gas burning components. Please contact Weber-Stephen Products LLC, Customer Service Department for genuine Weber-Stephen Products LLC replacement part(s) information.

**⚠ WARNING: Do not attempt to make any repair to gas carrying, gas burning, igniter components or structural components without contacting Weber-Stephen Products LLC, Customer Service Department. Your actions, if you fail to follow this Product Warning, may cause a fire, an explosion, or structural failure resulting in serious personal injury or death as well as damage to property.**



WEBER-STEPHEN PRODUCTS LLC  
[www.weber.com](http://www.weber.com)<sup>®</sup>