

2008  
Sportsmobile  
Manual

**GENERAL**

OTHER MFG SUPPLIED ITEMS	A
SAFETY - ALWAYS PRACTICE IT	10
WARNINGS	11
WEIGHTS - QUICK CHECKS	12
INSPECTION & MAINTENANCE SCHEDULE	13
SPORTSMOBILE LIMITED WARRANTY	14
MISCELLANEOUS INFORMATION	15

**SPORTSMOBILE**

INTERIOR CARE	20
EXTERIOR CARE	21
SEATS/BEDS	22
PENTHOUSE TOP (O)	23
PENTHOUSE WITH ELECTRIC LIFT (O)	24

**12V SYSTEM**

ELECTRICAL SYSTEM - SCHEMATIC	30
FUSE PANEL - CONVERTER/CHARGER	31
AUXILIARY BATTERY SEPARATOR	32
AUXILIARY BATTERY, GENERAL INFO	33
AUXILIARY BATTERY, CHARGING	34
AUXILIARY BATTERY DRAIN	35
12V SYSTEM TROUBLE SHOOTING	36
12V SYSTEM TROUBLE SHOOTING (cont.)	37
12V & 110V TYPICAL REQUIREMENTS	38
SOLAR PANELS (O)	39
DETECTORS - RADIO SWITCH (O)	40
REFRIGERATOR, ELECTRIC	41

**110V SYSTEM**

ELECTRICAL SYSTEM & GENERATOR	50
ELECTRICAL SYSTEM INFO	51
INVERTER (12V TO 110V) (O)	52

GENERATOR	53
GENERATOR INFO	54
GENERATOR OPERATING TIPS (O)	55
GENERATOR TROUBLE SHOOTING (O)	56

**PROPANE SYSTEM**

GENERAL INFO	60
OPERATION CONSUMPTION	61
PROPANE FURNACE (O)	62

**PLUMBING SYSTEM**

FRESH WATER SYSTEM, PUMP	70
FRESH WATER SYSTEM (cont.)	71
HOLDING TANKS	72
HOLDING TANKS DUMPING	73
MACERATOR PUMP	
WINTERIZING	74
WATER HEATER, 110V (O)	75
MACERATOR PUMP (O)	76

**STARCOOL AIR CONDITIONER (O)**

N/A SPRINTER

Please see back section this manual

SEE OTHER MANUFACTURER'S LITERATURE FOR ITEMS NOT INCLUDED IN THIS MANUAL

REFRIGERATORS	GENERATORS
STOVES	TOILETS
FURNACE	MACERATOR PUMP
WATER HEATERS	DIESEL APPLIANCES
POWER CONVERTER	4X4 CONVERSIONS
INVERTER	4X4 OPTIONS
SOLAR PANELS	AND OTHERS -that may have
AIR CONDITIONERS	been added since this printing.

**GENERAL**

Appliances and some options are supplied to Sportsmobile by outside manufacturers. Warranty cards must be completed and mailed as the various manufacturers instruct. Note: Some serial numbers may not be visible after the item is installed. Should you have a problem and the item is still under warranty, Sportsmobile's invoice to you will suffice as to purchase date proof.

**SPORTSMOBILE HAS REWRITTEN SOME MANUFACTURERS OPERATING INSTRUCTIONS TO MAKE THEM MORE USER FRIENDLY**

1. **THESE SHEETS ARE TO BE CONSIDERED ONLY AS SUPPLEMENTS TO THE MANUFACTURERS LITERATURE NOT REPLACEMENTS.**
2. **IT IS IMPORTANT THAT YOU READ AND UNDERSTAND ALL OF THE MANUFACTURERS LITERATURE BEFORE OPERATING ANY OF THESE ITEMS. SOMETIMES A SUPPLIER WILL CHANGE INFORMATION AND NOT ADVISE SPORTSMOBILE.**
3. **BE SURE TO CAREFULLY REVIEW THE MANUFACTURERS INFORMATION TO BE CERTAIN THERE IS NOT AN INFORMATION CONFLICT. SHOULD THERE BE ANY CONFLICT WITH SPORTSMOBILE SHEETS – FOLLOW THE MANUFACTURERS INSTRUCTIONS.**

**SERVICE**

1. **All appliances and options used by Sportsmobile are name brand and have been used by Sportsmobile for many years. Almost any RV service center can service them. Please see the Yellow Pages.**
2. **Some suppliers include a list of service centers in their literature that are approved for warranty work. Some also list phone numbers you can call if you have a question, problem, need to know the closest approved service center, etc.**

(O) These items are additional cost options and may not have been ordered with your Sportsmobile.

\* These items are not included in the Sportsmobile Owner's Manual. See manufacturer's literature for information.

**SUGGESTION:** Check the items that are included with your conversion.

- NORCOLD REFRIGERATORS:** Model DC-0051 (3CF), Model DE-0041R (4CF) (O), Model DE-0061T (7CF) (O), Available Sprinter only • 800-752-8654 [www.norcold.com](http://www.norcold.com)
- \*(O) **DOMETIC REFRIGERATORS:** Model RM 2202 (2CF), Model RM 2454 (4CF), Model RM 2663 (6CF). Available Sprinter only. • 800-544-4881 [www.domesticusa.com](http://www.domesticusa.com)
- \*(O) **SUBURBAN FURNACE, PROPANE:** Model NT-12 • 423-775-2131 [www.rvcomfort.com](http://www.rvcomfort.com)
- \*(O) **ESPAR MARINE AIR HEATER** • 800-387-4800 [www.espar.com](http://www.espar.com)
- \*(O) **SUBURBAN WATER HEATER, PROPANE:** Model SW6D • 423-755-2131 [www.rvcomfort.com](http://www.rvcomfort.com)
- \*(O) **FLAT PLATE WATER HEATER** • 800-774-0474 [www.flatplate.com](http://www.flatplate.com)
- \*(O) **IN-SINKERATOR, 110V WATER HEATER** • 800-558-5700 [www.insinkerator.com](http://www.insinkerator.com)
- (O) **STARCOOL AIR CONDITIONER • SPORTSMOBILE OR** • 214-328-8541 [www.danhard.com](http://www.danhard.com)
- POWER CONVERTER:** Model PD 1260C, Progressive Dynamics • 269-781-4241 [www.progressivedyn.com](http://www.progressivedyn.com)
- \*(O) **TRIPP-LITE INVERTER. 2000W** • 773-869-1233 [www.triplite.com](http://www.triplite.com)
- \*(O) **XANTREX INVERTER. 2000W** • 408-987-6030 [www.xantrex.com](http://www.xantrex.com)
- AUXILIARY BATTERY, AGM DEKA** • 610-628-4781 [www.eastpenndeka.com](http://www.eastpenndeka.com). NOTE: AGM batteries are manufactured by several different companies. Check your battery label.
- \*(O) **KYOCERA SOLAR PANELS** • 800-223-9580 [www.kyocerasolar.com](http://www.kyocerasolar.com)
- \*(O) **SOLARA SOLAR PANELS** • [www.solaraenergy.com](http://www.solaraenergy.com)
- \*(O) **ONAN GENERATOR:** Consult the yellow pages, or call 800-888-6626. [www.cumminsonan.com](http://www.cumminsonan.com)
- (O) **THETFORD PORTA POTTI 585 / BRAVURA MARINE TOILET** • 800-521-3032 [www.norcold.com](http://www.norcold.com)
- SHURFLO WATER PUMP:** Model 2088-403-144 • 800-854-3218 [www.shurflo.com](http://www.shurflo.com)
- \*(O) **MACERATOR PUMP** • 978-281-0440 [www.flojet.com](http://www.flojet.com)
- \*(O) **FIAMMA AWNING** • 407-672-0091 [www.fiamma.com](http://www.fiamma.com)
- \*(O) **FANTASTIC VENT ROOF VENT** • 800-521-0298 • 810-724-3831 [www.fantasticvent.com](http://www.fantasticvent.com)
- \*(O) **QUIGLEY 4X4 CONVERSION** • 800-233-9358 [www.quigley4x4.com](http://www.quigley4x4.com)
- \*(O) **SPORTSMOBILE WEST 4WD CONVERSION** • 800-827-3071

**“WARNINGS” ARE TO ALERT YOU TO PRECAUTIONS THAT INVOLVE YOUR PERSONAL SAFETY AS WELL AS VEHICLE DAMAGE. READ AND FOLLOW THEM CAREFULLY.**

Also see other warnings noted in this manual, van chassis and other manufacturer's literature.

#### **WARNING - POWER CORD**

**Do not** plug the power cord into an outlet that is not grounded, or adapt the plug to connect to a receptacle for which it is not designed.

Be sure that all three prongs of the supply cord are properly plugged into the receptacle.

**Do not** connect the power cord to an extension cord.

**Do not** connect the external power cord to any receptacle until you have used a tester to check the polarity and grounding.

It is the responsibility of the owner of the electrical receptacle to ensure that the receptacle is properly wired and grounded.

Reverse polarity and improper grounding of the vehicle can cause personal injury or death.

#### **WARNING - GFI**

The GFI will not completely eliminate electrical shock. Small children and persons with heart conditions or other disabilities, which make them especially sensitive to electrical shock may still be injured by 110V receptacles even though protected by a Ground Fault Interrupter.

#### **WARNING - LP GAS**

**Do not fill container to more than 80% of capacity.** Make sure the motorhome is level when filling. It is possible to accidentally overfill the tank if the vehicle is not level, with the fill valve on the uphill side. Over-filling the LP gas tank can result in uncontrolled gas flow, which can cause fire or explosion. A properly filled container will contain approximately 80% of its volume as liquid LP gas.

**All pilot lights must be extinguished** and supply valve closed before refilling LP gas tanks or vehicle fuel tanks.

**Do not smoke or expose an open flame** while near an LP refueling area, LP gas is heavier than air and extremely flammable.

**Never** fill the LP tank with the engine running.

**Never use an open flame** to test for LP gas leaks.

**Replace** all protective covers and caps on LP system after filling.

**Do not** alter or remove LP tank gauge at any time.

**Do not** hold gas valve in more than 30 seconds when lighting appliances. If the flame is not indicated within this time, turn the gas at the selector switch off, and wait 2 minutes and retry. Continuing to hold the gas valve in will cause gas to build up in the burner area and can result in an explosion, which can cause personal injury or property damage.

Inspect the pressure regulator vent hole periodically for blockage. If any obstruction is apparent, have the regulator serviced by your dealer or a qualified LP gas service center. LP gas regulators are installed with the diaphragm vent facing downward. Make sure that the regulator vent always faces downward to minimize vent obstruction that could result in excessive pressure, causing a fire or explosion.

#### **WARNING - STOVE**

It is not safe to use cooking appliances for space heating purposes due to the danger of esphyxiation.

**Do not** turn burner control knob to “On” and allow gas to escape before lighting match. The stove needs fresh air for

safe operation. When using the stove, raise the Penthouse Top (O) and open a side flap to provide additional ventilation.

#### **WARNING - FLAMMABLE LIQUIDS**

**Do not** Place LP gas containers, gasoline, or other flammable liquids inside the vehicle. LP gas containers are equipped with safety devices, which relieve excessive pressure by discharging gas to the atmosphere. Fire or explosion may result.

#### **WARNING - FIRE EXTINGUISHER**

**Do not** test the fire extinguisher by discharging it. Partial discharge can cause leakage of pressure or contents that would render the unit inoperative when needed. When using the fire extinguisher, aim the spray at the base of the fire.

The fire extinguisher should be inspected monthly for proper charge and operating condition. This should also be done before beginning a vacation or any extended trip.

#### **WARNING - PENTHOUSE TOP (O)**

Lock top down prior to driving — all 3 latches. Latches have screw adjustments to ensure top is snug to van's roof. See Penthouse, page 21.

**Do not** release latches or raise top when driving.

#### **WARNING - BEDS**

**Do not** use sleeping facilities while vehicle is moving. Buckle up,

#### **WARNING - CHASSIS MANUAL**

Before driving your vehicle, be sure you have read the entire operator's manual and that you understand your vehicle's equipment completely and how to use the equipment safely.

**MOTORHOME WEIGHT INFORMATION**

**Sportsmobile**

**GVWR (Gross Vehicle Weight Rating)** is the maximum permissible weight on this fully loaded motorhome.  
**UVW (Unloaded vehicle weight)** is the weight of the motorhome as manufactured at the factory with full fuel, motor oil and coolants.  
**SCWR (Sleeping Capacity Weight Rating)** is the manufacturer's designated number of sleeping positions multiplied by 154 lbs (70 kg).  
**CCC (Cargo Carrying Capacity)** is equal to GVWR minus each of the following: UVW, full fresh (potable) water weight (including water heater), full LP gas weight and SCWR.

<b>Cargo Carrying Capacity (CCC) Computation</b>	<b>Pounds</b>
<b>GVRW</b> .....	
<b>Minus UVW (Approximate)</b> .....	
<b>Minus Fresh water weight of 16@8.3 lb/Gal</b> .....	
<b>Minus Propane Weight of 0 @ 4.2 lb/Gal</b> .....	
<b>Minus SCWR 4 Persons @ 154 lb/Person</b> .....	
<b>= CCC for this Motorhome* (Approximate)</b> .....	

**\*Dealer Installed Equipment and towed vehicle tongue weight will reduce CCC**

**WEIGHT DISTRIBUTION** consideration has been given to the weight distribution of the Sportsmobile conversion. When loading your Sportsmobile you should also consider the weight distribution of your cargo. Do not overload your tires.

**WEIGHING YOUR SPORTSMOBILE** can be done at any certified weight station. Most truck stops and moving companies have scales. See "Scales" in the Yellow Pages.

**WARNING:** Consult owner manual(s) for specific weighing instructions and towing guidelines including auxiliary brake requirements for any towed trailer or towed vehicle.

Per RVIA 3/28/05

**BEFORE DRIVING ALSO SEE SPORTSMOBILE MANUAL**

- **Penthouse Top (O)- WARNING:LOCK DOWN FRONT/REAR**
- **LOOSE CARGO/OBJECTS-SECURE/STOW**
- **CAPTAINS SEATS-FACE FORWARD/BACK UPRIGHT**
- **SHORELINES-DISCONNECT**
- **PROPANE GAS VALVE-CLOSE**
- **HAVE YOU LEFT ANYTHING? BUCKLE UP!**

**WHEN DRIVING**  
**DO NOT USE**  
**TABLE, STOVE, TOILET,**  
**BED, SEATS W/O BELTS**

**QUICK CHECKS**

- **MAIN BREAKER-** Switch "Off" before plugging or unplugging extension cord to 110V hookup.
- **EXTENSION CORD-** 30 amp approved cord supplied to connect to 110V hookup.
- **110V ADAPTOR CORD (30 TO 15)-** Limits appliance usage, may trip 110V circuit breaker.
- **WATER TANK-** Turn valve "Off" after filling.
- **APPLIANCE DOESN'T WORK?** First, verify power is entering van. See Sportsmobile Owners Manual.
- **A/C, IF USING GENERATOR-** Wait 3 minutes before restarting. Turn A/C "Off" before starting van.
- **RADIO SWITCH (O)-** Switch should be set to "Van's Battery" when not in use.
- **TV SWITCH (O)-** Turn "Off" when not in use to prevent battery drain.
- **INVERTER (O)-** Turn off when not in use. Turn "On" when connected to 110V hookup.
- **DETECTORS-** Remove 3amp fuse if van will not be used for a week or so to prevent battery drain.

**WARNING-** Reinstall fuse prior to using the van. If detector makes low beep, your auxiliary battery is getting low.

**MAINTAIN- ALSO SEE SPORTSMOBILE'S OWNERS MANUAL.**

- **GENERATOR (O)-** Operate at least 2 hours continuously at 1/2 load every month. See Sportsmobile's Owners Manual.
- **STARCOOL A/C (O)-** Operate on 12V and 110V for 10+ minutes each month. Check air filter each month. Unscrew and remove vent in front of Starcool evaporator, wash in water and replace.
- **TIRE PRESSURES-** See label on drivers doorpost.

**SOMETHING NOT WORKING?**

- **A/C, FURNACE, WATER PUMP, ELECTRICAL SYSTEM, ETC?-** Please see Sportsmobile Owners manual.
- **Suggestion-** Review Sportsmobile Owners Manual periodically.

**DATES CHECKED**

**EVERY MONTH**

- Operate - Starcool A/C on 110V for 10 min.
- Generator - Run 2 hrs. every 4 wks at half load
- Detectors - Test All
- GFI - Test
- Fire Extinguisher - Check Charge gauge

**EVERY SIX MONTHS**

- Starcool - Clean filter, condensor fans (2)
- Propane Leaks - Inside fittings
- Water Leaks - " " "
- Propane Lines - Under van, OK?
- Electrical Lines - " " "
- Holding Tanks - Straps secure
- Dirt Dobbers - Furnace, water drains
- Sliding Windows - Clean drain slots
- Wax - fiberglass Top, Running Boards

**PERIODICALLY**

- Propane Water Heater - Anode Rod
- Furnace - See Mfg's Lit.
- Refrigerator - See Mfg's Lit.

**STORING**

- Generator - See Mfg's Lit.
- Propane Tank - turn off master valve
- Auxiliary Battery - disconnect negative ground wire to prevent any drain.
- Clean - Interior and Exterior
- Penthouse Sidewalls - Clean and dry
- Connect van to shore power when possible.

**WINTERIZING PLUMBING**

**Note:**

- **Mark through items** that do not apply to your Sportsmobile.
- **Is this list complete?** Add any items you may have that are not included in the above.
- **Also see your Sportsmobile manual** and other manufacturers literature for more information.
- **4x4 See 4x4 Maintenance and Schedule**
- **The Van Chassis** See the Manufacturer's literature

**SPORTSMOBILE**

Sportsmobile North Inc. (Formerly Sportsmobile Inc.), Sportsmobile Texas Inc., and Sportsmobile West Inc. are individual corporations and warranties only the Sportsmobiles each has manufactured. However, in most all cases, each company will service a Sportsmobile that one of the other companies has manufactured. However, some parts and options may be excluded if that company does not offer that item. We all work together!

**WHAT IS COVERED?**

This "Limited Warranty" applies to the original retail purchaser and is not transferable. Sportsmobile will repair, or at its option replace, any defective or malfunctioning part of that conversion other than those exceptions noted in this warranty. This warranty applies only to repairs necessary due to factory defects in materials or workmanship, and resulting from normal use of the recreational vehicle. Warranties for components excluded from this warranty are the sole responsibility of their respective manufacturers. This warranty applies to Sportsmobile products sold and normally operated in the United States or Canada. Warranty protection for vehicles sold and operated outside these areas may differ.

**HOW LONG COVERAGE LASTS**

The warranty period is 50 months or 50,000 miles from date of first retail delivery, whichever comes first.

**REPAIR POLICY**

Sportsmobile will make necessary warranty repairs to your vehicle at no charge for parts or labor. A reasonable time must be allowed for repair work. Parts and labor for normal or required maintenance are not included under warranty. If you are not in an area within a reasonable distance of Sportsmobile, as determined by Sportsmobile considering the nature of the problem, service may be obtained at a mutually acceptable alternative service point. **However, authorization to have the work performed must first be obtained from Sportsmobile.** Such authorization does not constitute endorsement of the service point, this work, or any replacement components involved, not supplied or otherwise used by Sportsmobile.

**WHAT IS EXCLUDED?**

Conditions resulting from abuse or neglect, such as overloading, accident, improper or insufficient maintenance, improper repairs, normal wear and tear, chips, dents or scratches or environmental damage (theft, vandalism, riot, fire, or explosion or driving through water deep enough to cause damage) are not covered by this warranty. Also excluded" the automotive chassis and options; separately warranted products, see below; custom paint/vinyl stripes, fiberglass top/running boards finish, pleated shades or window glass breakage. The warranty will not apply if the odometer has been altered or the vehicle has been issued a "salvage" or some other title under any state law.

This warranty also does not cover consequential damages or economic loss. This includes, without limitation, loss of use of the vehicle, expense for alternate transportation, lodging bills, the cost of bringing the vehicle to a service point, or loss of income. Some state do not allow the exclusion or limitation of incidental or consequential damages, so the above limitation or exclusion may not apply to you.

**SEPARATELY WARRANTED PRODUCTS ARE EXCLUDED**

Sportsmobile companies warrant only the parts manufactured and supplied by the named Sportsmobile company that converted your van. 4X4 conversions are covered under a separate warranty offered by that manufacturing company. The listed Sportsmobile companies do not assume any responsibility or liability of defects in the workmanship or operation of the van chassis itself or of other separately warranted products such as refrigerators, furnaces, generators, air conditioners, etc. The individual manufacturers offer warranties for these products. A copy of their warranty and other information has been included in your owner's packet. In order to obtain repairs or replacement of these items, the individual manufacturer's warranty cards must be submitted. Some appliance serial numbers may be hidden during their installation. If they are, a copy of our dated invoice will establish the start of the warranty time.

**IMPLIED WARRANTIES**

Any implied warranty of merchantability of fitness for a particular purpose applicable to this vehicle is limited to the duration of this limited warranty. Some states do not allow limitations on how long an implied warranty will last, so the above limitation may not apply to you.

**OTHER ITEMS**

This is the only express warranty applicable to Sportsmobile products. Sportsmobile does not authorize any person to create for it any obligation or liability in connection with this vehicle. The performance of repairs and needed adjustments is the exclusive remedy under this written warranty or any implied warranty. This warranty gives you specific legal rights, and you may also have other rights which vary from state to state.

**PRODUCT CHANGES**

Sportsmobile reserves the right to make product changes, and improvements without imposing any obligation upon itself to install the same upon products theretofore manufactured

**SUGGESTIONS**

- REVIEW THIS MANUAL AND THE OTHER MANUFACTURER'S LITERATURE PERIODICALLY
- DELETE SHEETS IN THIS MANUAL THAT DO NOT APPLY TO YOUR SPORTSMOBILE
- KEEP THIS MANUAL IN A CONVENIENT LOCATION FOR QUICK REFERENCE.

**SPORTSMOBILE POST CARDS** — We are including some Sportsmobile post cards in the back of this manual. These can be given to anyone who expresses an interest in your Sportsmobile. This may be more convenient for you than having to answer a lot of questions when you are busy watching the birds, contemplating life, etc. If the person is interested they can contact us for a literature package. They can also see our website. Should you run out please let us know - we will be very happy to send more.

**VEHICLE LOADING** — Sportsmobile offers lots of options. It's your responsibility to safely manage your loads so that they remain within the manufacturers specified chassis weight limits. Do not overload your Sportsmobile. Plug van into shore power whenever possible to keep batteries fully charged.

**TIRES** — It's very important to keep them properly inflated and in good condition. See the driver's seat area/door post for proper inflation. See your chassis owner's manual for more important information.

**CONNECT TO 110V** — Outside hookup when possible to keep your Auxiliary Batteries fully charged.

**SPARE TIRE LOCK** — Keys will be attached to your van keys, for the spare tire and continental tire cover (O) lock. A separate wrench is included (the van's lug wrench will not fit the tire lock nut.)

**TV** — See manufacturer's literature for operating temperatures and other information. When traveling, always stow the TV in a safe position.

**RV/TRAVEL LINKS** — We have listed a number of links on our website that may be of interest to you • RV Service/Supplies • Interesting Reading • Travel Information • State Travel Guides • Public Lands • Travel Clubs • See [www.sportsmobile.com](http://www.sportsmobile.com), main menu button, "Information" then the "RV/Travel Links" button.

**GENERAL INFORMATION** — • Electrical • Plumbing • Propane Systems. See our site — main menu button "Information" the "Systems Info" button.

NOTES \_\_\_\_\_

\_\_\_\_\_

\_\_\_\_\_

\_\_\_\_\_

\_\_\_\_\_

\_\_\_\_\_

\_\_\_\_\_

\_\_\_\_\_

\_\_\_\_\_

\_\_\_\_\_

\_\_\_\_\_



**Countertop — Solid Surface (O)**

1. **Solid Surfacing** is formulated from high-tech composite of polyester-acrylic resins and natural minerals — giving the perception of stone. It's 100% solid — the color goes all the way through the material. It is chemically engineered to resist stains, nicks and scratches. It is non-porous and does not support the growth of mold, mildew and bacteria.
2. **Solid Surfacing withstands heat** better than most countertop materials, however, hot pans, as well as some heat generating appliances like crock pots, can damage the surface. Always use a hot pad or trivet with rubber feet to protect your top.

**Removing Minor Cuts and Scratches**

1. Use a green Scotch Brite® pad in a circular motion. Wipe area clean.
2. Restore finish with a non-abrasive cleaner and white Scotch Brite® pad.
3. Polish with Quick Shine® Plus.

**Cleaning and Sanitizing**

**Most dirt and stains** — Use a damp cloth or O-Cel-O™ with soapy water or ammonia based cleaner.

**Water Marks** — Wipe with damp cloth, towel dry

**Difficult Stains** — Use SoftScrub® or diluted bleach and whit Scotch Brit® pad.

**Sanitizing** — Occasionally wipe surface with diluted bleach, 50/50 solution.

**Maintenance** — Rub with white Scotch Brite® pad alone and polish with Quick Shine® Plus.

**DAY/NIGHT SHADES**

**Due to the nature of the pleated shade design**, pleats at the bottom will be fuller than those at the top. To maintain the crispness of pleats, shades should be raised on a regular basis and left in the raise position as long as possible. Use care when lowering or raising the shades as they can easily be damaged.

**SHADE ADJUSTMENT** — If the pleated shades have a tendency to lower while driving, remove the bottom track, slide the plastic cover to one side, exposing the strings and spring. Shorten the length of the strings to increase spring tension, reassemble and replace. If the top track of the pleated shade comes unlatched from its clips, reinstall it by twisting it into the latches. If it continues to unlatch, replace the mounting brackets. Call Sportsmobile and we will send them to you. The top track can be shifted to the left or right to maintain a level pleat while raising or lowering the shade.

**CUSTOM PAINTED STRIPES (O)**

1. To permit the automotive acrylic paint to "cure out." you should not wash or polish the custom paint for 30 days.
2. Your custom paint has a clear hardener coat applied over the custom paint. To help preserve the beauty of your van's finish, we suggest you wash your van with cool water and a mild detergent. The codes for the custom paint are listed on the driver's side door post.
3. For the van's base paint color care - please see the van's owner's manual. Base van color touch-up paint is available from your local dealer.

**AUTOMOTIVE VINYL STRIPES (O)**

1. These stripes require little maintenance. They should be treated similarly to a painted surface. They are manufactured with a UV protectant.
2. Wash the graphics with plain soap and water or any car wash soap. Make sure to rinse thoroughly.
3. Keep high pressure nozzles at least 3 feet from the edge of the graphics. High pressure spray may cause the edge of the graphic to peel.
4. Test any cleaning solution on a small section of the decal before using.
5. Do not use any type of solvents on the graphics. Solvents may damage the stripes.
6. Do not apply wax over graphics. Wax that has dried between stripes can be removed by softening it with rubbing alcohol and cotton swabs. Be sure to rinse with water after cleaning.

**FIBERGLASS TOPS & RUNNING BOARDS (O)**

1. Waxing is recommended periodically throughout the year. It helps protect the fiberglass from normal, common elements.
2. Many over-the-counter auto waxes are available for this application. Check the product for use and application.
3. DO NOT WAX IN DIRECT SUNLIGHT!

**"GEL COATED SURFACES" — FIBERGLASS TOP & RUNNING BOARDS**

1. If the fiberglass part is white or off-white, most likely the white color is in the gel coat and it has not been painted.

**WHY MUST I DO ANYTHING TO PROTECT THIS GELCOATED SURFACE?**

1. Most all colored gel coat and painted surfaces have the tendency to be attacked by the ultra violet rays of the sun. The result of the attack is color fading, yellowing and/or a dull chalky look.
2. There is also the possibility of stains from contact with various chemical products. A simple maintenance plan can help greatly in reducing these problems.

**WHAT SHOULD I WATCH FOR?**

1. If salt has collected on the surface it is wise to remove it as soon as possible. Road tar can leave a stain if left for a long period of time.
2. Remember, if it's bad for your vehicle, it's likely to be bad for the fiberglass part.

**HOW SHOULD I CLEAN IT?**

1. Use mild biodegradable soap with warm water to clean the fiberglass surface. Dry thoroughly with a clean soft cloth. Do not use abrasive or solvent base cleansers.

**CAN STAINS BE REMOVED?**

1. Most stains can be removed by using a cleanser that is made specifically for gel coated surfaces. Check a marine supply center or auto parts store for an applicable product.
2. If remover cannot completely remove the stain, you may wish to hand rub the small area with a fine automotive compound.
3. When removed, rinse with clean water, dry and apply a good coat of wax.

**EXPANDABLE TOP (O)**

1. The side wall should be washed with warm soapy water occasionally. Rinse thoroughly.
2. The Fiberglass top, please see above.

**GAUCHO & DINETTES L & W**

**TO MAKE SEATS INTO BED**

1. Release back cushion top restrainer straps.
2. Raise seat cushion front up several inches and slide out.
3. Drop back cushion into position between seat cushion and van wall.

**TO MAKE BED INTO SEAT**

1. Grasp strap sewn to bottom of back cushion. Pull cushion up.
2. Raise seat cushion front up several inches and slide back.
3. Secure back cushion top straps to tops of steel supports.

**SEAT BELTS**

1. If a seat is not equipped with a seat belt this seating position is not a designated seating position for travel.

**WARNING** - Seat belts may slide between cushion and wall. If so, pull into position for use.

**STORAGE ACCESS**

1. Swing seat cushion up.
2. Raise support rod to hold seat cushion up for easy storage access.

**WARNING** - Secure seat backs when traveling. **BUCKLE UP!**

---

**CAPTAIN SEATS**

1. To slide fore/aft - pull lever under left front corner of seat cushion to release slider lock.
2. To swivel passenger seat - slide seat all way forward. Move seat back to upright position, then unlock swivel by pulling lever on side of seat base. To swivel the driver's seat you may have to open the driver's door until the seat is in a position where you can close the door.

**WARNING** - Seat backs must be upright and facing forward when traveling. **Buckle up.**

**WARNING** - DO NOT swivel seats more than 180°. If you do, you may disconnect seat belt wires. Swivel "inward," then back in the same direction.

**TO ELEVATE**

1. Unlock front and rear latches, unhook the front and rear bed hooks/ This will lessen the weight of the top and make it easier to raise.
2. Open a door or window to relieve air pressure.
3. Push up using front handles. Note: Be sure the front hold down "J" hooks are clear of front sidewalls, as the hooks could damage the sidewalls of front screen when the top is raised.  
**WARNING:** Do not operate the top if you have a neck, back or some other physical problem as it could aggravate your condition.
4. To lower the bed. First, unhook the rear of the bed and carefully lower to the bottom support rails. Then unhook the front and lower. The bed can be slid to the front or rear of the top opening.

**TO LOWER**

1. Close front flap and vinyl side windows. If you do not close the front flap the "J" hooks could damage the front screen the next time you raise the top.
2. Open a window or door to relieve air pressure.
3. To lower the top - unhook bed "rear" only. Leave the front of the bed hooked to the ceiling. The weight of the front of the bed will make it easier to lower the top.
4. Pull Down. Do not pull down too fast, as this will cause the sidewalls to "balloon" out.
5. Note: Stop the top when it is about half way down. "Bump" the front corners forward. This will cause the front side walls to fold forward and look neater.
6. Lock front and rear latches  
**WARNING: Lock top down before driving.**

**IF TOP DOES NOT LINE UP IN VAN DRIP RAILS WHEN DOWN**

1. If you are not parked on level ground, the top will pull to the lower side. To compensate, pull the top slightly to the opposite side when lowering. Or, you can push the top into the drip rail after it is lowered and before it is locked down.
2. The top "floats" on the dual U-tubes inside the upholstered compartments that are bolted through the roof. Over time the top can slowly work its way over to one side or the other. To correct this, have one person raise and hold the top about 12" up. Have a second person from outside the van push the top over to the opposite side. By some trial and error the top can be realigned with the van drip rails.

**MAINTENANCE**

1. There's really little to do.
2. Occasionally you may need to adjust the 3 lock down latches by turning the "J" bolt hooks. When the top is locked down, all 3 latches should be snug.
3. The sidewalls should be washed with warm soapy water occasionally.
4. Every 6 months or so the rubber bumper around the penthouse shell should be sprayed with silicone.
5. Decorative plastic caps on top of the Penthouse shell can deteriorate over time. Please call Sportsmobile to have free replacement caps sent.
6. Fiberglass top, see page 21.

**WARNING:** Do not loosen the lock-down "J" bolts to less than 4 threads.

The **Penthouse Top Electric Lift Option** allows you to raise and lower the Penthouse Top with a load placed on it. The maximum recommended load is 150 pounds, when centered front to rear and side to side. You will want to exercise caution when raising or lowering the Penthouse Top as the lift actuators are very powerful and can cause damage if the following procedures are not followed.

---

To **“raise” Penthouse**, the following procedures must be followed.

- Release all three (3) hold-down latches.
- Confirm that all three (3) Penthouse bed straps are attached.
- Open door or window to allow air to enter as top is raised.
- Press and hold “up” rocker switch to raise top. Confirm top is elevating level and that none of the Penthouse latches have “hooked” onto the latch plates.

---

To **“lower” Penthouse Top**, the following procedures must be followed

- Close all screens and windows completely.
- Attach Penthouse bed to ceiling.
- Open door or window to allow air to escape as top is lowered.
- Press and hold the “down” rocker switch to lower top until it is all the way down
- Secure all three (3) hold-down latches.

---

If the **Penthouse Top Electric Lift does not operate** when trying to raise or lower it, you will need to confirm that the house battery voltage is at least 12 volts minimum. If the battery voltage is okay, confirm that the 30 amp driver side fuse located under the sofa is okay by verifying the lights on the driver side operate. If the lights operate, then the fuse is good, if they don't operate, replace the 30 amp fuse.

If you've confirmed the 30 amp fuse is good, you'll need to check the Penthouse Top Electric Lift circuit breaker. There is an auto-reset 6 amp circuit breaker located in the wall behind the Penthouse Top Electric Lift rocker switch. You'll need to remove the two (2) Phillips head screws and the switch to access this circuit breaker which is inline on the red 12 volt positive wire. 12 volt power should be present on both terminals if the circuit breaker is good. Replace this circuit breaker if there is not 12 volt power on both terminals. On early models, the 6 amp circuit breaker was mounted behind the plastic seatbelt trim on the driver door post and is not easy to access. You can confirm the 6 amp circuit breaker is good if there is 12 volt power present at the switch.

If the circuit breaker is good, confirm 12 volt power is passing through the switch when activated. Replace switch if no 12 volt power passes through it when activated.

---

Contact Sportsmobile West at 800-827-3071 if further service is needed.

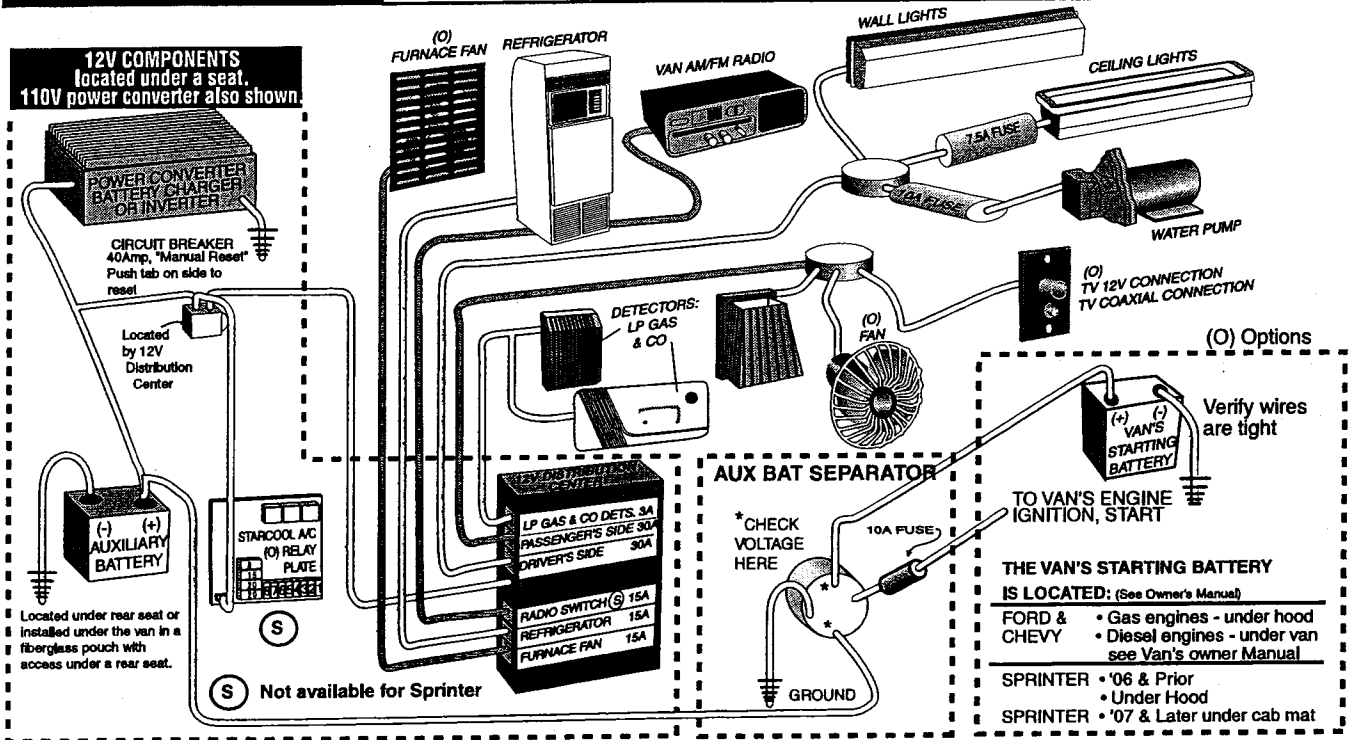

**ELECTRICAL SYSTEM, 12V** (See your van operator's manual for the van's 12V system.)

1. The 12V system supplies 12V power to all 12V items when driving or parked.
2. The only items that continuously draw power from the Auxiliary Battery are the Propane/Smoke Detector and the C.O. Detector and other items, such as a TV. They draw a total of 9 amps or more per 24 hours.

**12V FUSES & CIRCUIT BREAKER LOCATIONS**

1. See "12V Distribution Center" drawing above and separate "12V Schematic" page. Other 12V fuse locations:
  - Ceiling Lights - At front upper opening of top, driver's side.
  - Water Pump - Next to Pump.
  - Starcool Air Conditioner - Next to 12V Distribution Center.
2. If new fuse blows when installed, have wiring checked for a short. Check appliance ground when new fuse is installed.
3. A Manual/Reset Circuit Breaker, 40 amp, is located by the 12V fuse panel. To reset see Battery Separator page.

**IMPORTANT**

Your vehicle's electrical system should not be subjected to changes and/or additions to circuitry without consulting your dealer or Sportsmobile.

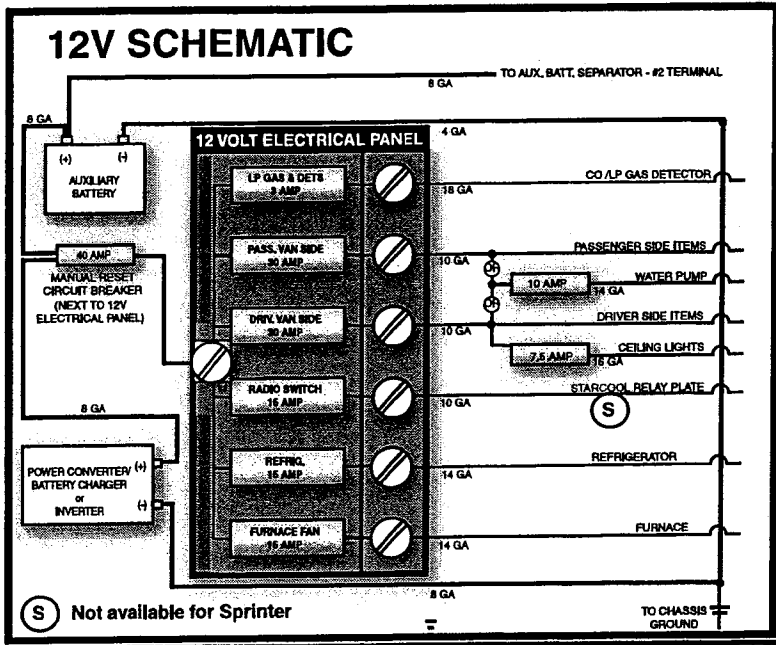

✓ Sprinter

✓ Ford & Chevy/GM

## 12V - FUSE PANEL-CONVERTER/CHARGER

# 31

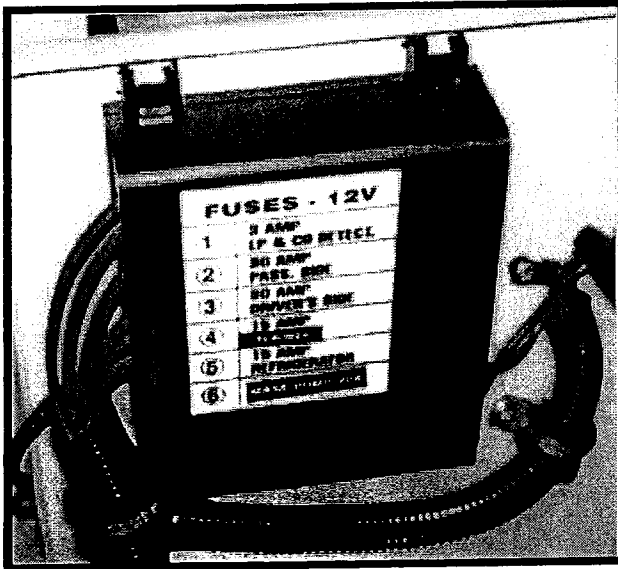

### 12 VOLT FUSE PANEL

Usually located under a rear seat. Front panel hinges up for fuse access. Note the fuse panel numbers with the fuse size. These blade type fuses are available at automotive stores.

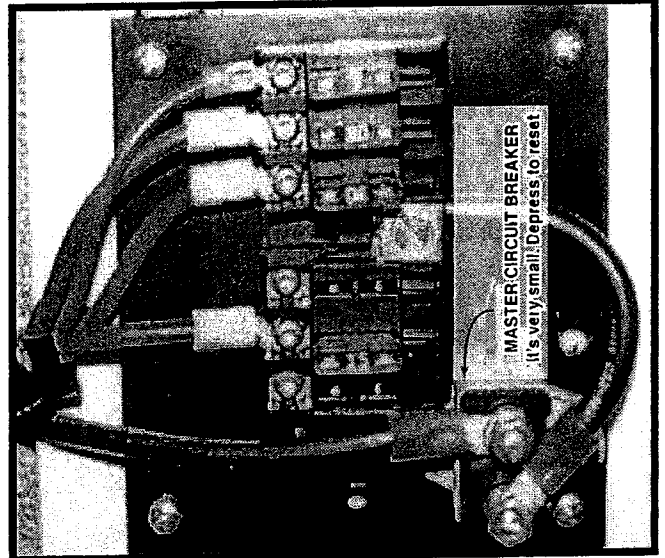

### 12V PANEL COVER OFF

If 12V lights and other 12V items don't come on, the master 40 Amp circuit breaker may have tripped. To reset, see above. If it continues to trip have a technician check it.

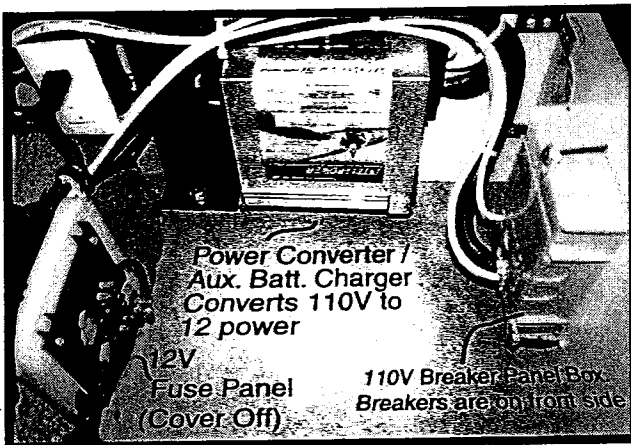

The above items are usually located under a rear seat. The arrangement varies.

**Do not stow items in this area!**

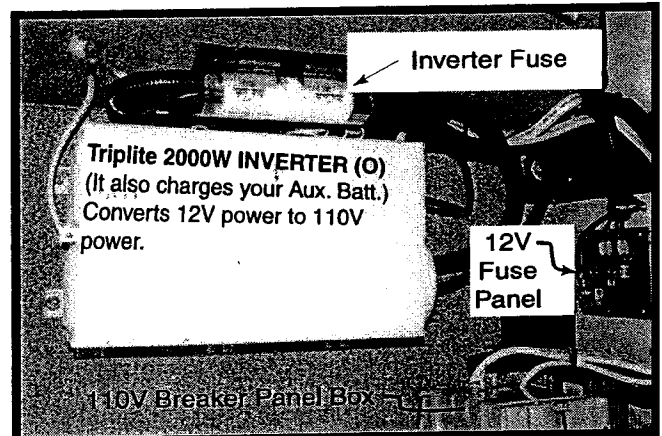

Inverter may be ordered, additional cost, in place of the Std. Equip. Pkg power converter/charger, shown in left photo.

### ■ POWER CONVERTER / BATTERY CHARGER

1. Sportsmobile's Power Converter / Battery Charger with the "Intelligent" Charge Wizard, includes some unique features. Plus it will safely charge your Auxiliary Battery in several hours, while others will trickle charge over a couple of days. It also produces less heat.
2. The 60A Converter / Charger provides 12V power to the Auxiliary Battery and 12V lights, fan, water pump, etc. when connected to a 110V hookup or running your generator (O).
3. The Charger will not overcharge your batteries. It is totally filtered, regulated and spike protected. Charging of the Auxiliary Battery system is automatic — there is no switch to turn off.
4. The Converter/Charger when supplying power will become warm. This is a normal occurrence. It is important that the area around the converter be left open for adequate ventilation.

**AUXILIARY BATTERY SEPARATOR** prevents your Van's Starting Battery from being discharged when you are parked and using 12V items such as 12V light, fan, etc. The only Sportsmobile items wired into the van's starting battery's wiring system is the radio switch when set to Auxiliary Battery. The radio switch is not available for Sprinter

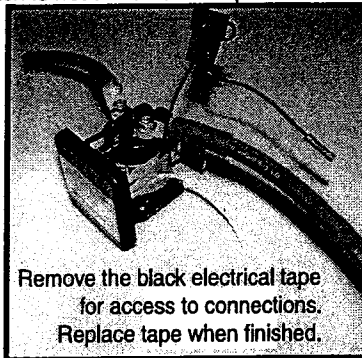
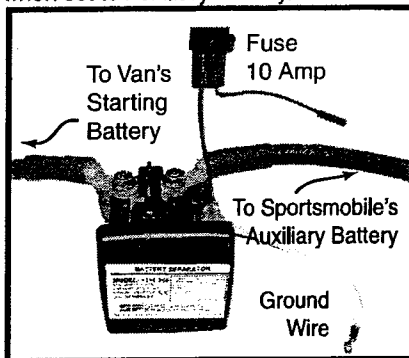

Should the Separator's fuse blow, no charge from the van's alternator will go to the Aux. Batt.

**Ford/Chevy** - Fuse is located close to the Separator. See photo.

**Sprinter** - Fuse is located in Driver's Seat base. See photo.

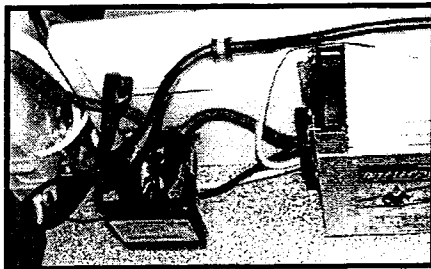

**Ford/Chevy Battery Separator Location** — Normally under a rear/front seat near the 12V fuse panel

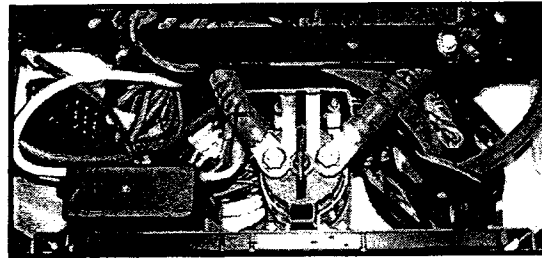

**Sprinter Battery Separator Location** — Under the Driver's Seat. Slide seat forward and remove protective panel.

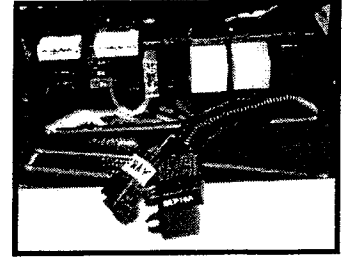

The Separator "fuse" is located in the driver's seat base where the Sprinter van fuses are located. For access remove the cover and pull out the 10 amp fuse holder. Marked "Sep 10A."

If seat has a swivel it will be necessary to unbolt seat (4 bolts). Then unbolt the swivel from the base.

**THE AUXILIARY BATTERY SEPARATOR** (Model 1215-200) is designed to protect the van's charging system from excessive loading while allowing auxiliary batteries to be charged.

There are two basic operational characteristics:

1. PROTECT THE CHARGING SYSTEM

- The BATTERY SEPARATOR monitors the battery system to determine if the batteries are being charged.
- When the engine or auxiliary batteries reach 13.2 volts, indicating charging is taking place, the BATTERY SEPARATOR will engage, joining the van starting battery and auxiliary battery.
- If the drain on the charging system by the auxiliary or van battery reduces the system voltage below 12.8 volts, the BATTERY SEPARATOR will disconnect the starting battery and the auxiliary battery from each other, thus protecting the respective batteries from excessive drain.
- When engine is not running and key is off, Separator disconnects both batteries - they are "isolated."

2. ASSIST IN ENGINE STARTING

- When the van's ignition is turned to start, the BATTERY SEPARATOR compares the voltage of both the van and auxiliary battery.
- If the van's battery is lower than the auxiliary battery, the BATTERY SEPARATOR will engage allowing the auxiliary battery to aid in vehicle starting. The start signal must be at least three volts for the operation to occur. A delay function has been incorporated in the control circuit to prevent the BATTERY SEPARATOR from reacting to momentary voltage fluctuations and chattering.

**Sportsmobile Auxiliary Battery** One battery is included in Sportsmobile's "Standard Equipment Package." An additional one is an option. Sportsmobile uses AGM batteries. The batteries are sealed, no maintenance is required.

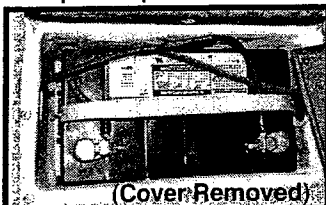

Battery is installed under the van's floor in a fiberglass pouch or under a Dinette seat in this picture. A second auxiliary battery, if ordered, would be under the opposite side.

- If the auxiliary battery or batteries cannot be installed under the van, they will usually be located under a seat. For access unscrew top protective seal panel. Photo to right shows one Std Equip Aux Batt and a second optional one.





**GENERAL INFO**

1. The Auxiliary Battery, or Batteries if you ordered an optional second one, will supply 12V power accessories, while driving or parked.
2. The standard size number 27 AGM 100 amp Battery supplied is a deep cycle, heavy duty battery. It is specifically designed for continuous use in deep cycle applications and it can be recharged hundreds of times. The much larger 4D size battery is equal to two number 27 batteries. Due to its size, the installation location is much more limited. It's sealed – there is no maintenance.
3. When your van engine is running, both the van's starting battery and Sportsmobile's Auxiliary Battery will be charged by the van's alternator. The larger the alternator, the faster the batteries will be charged. The alternator will only charge the Auxiliary Battery to 85-90% capacity. You must connect to shore power or confirm solar panels (O) or charging the Auxiliary Battery.
4. To charge your battery: Start your van's engine so the van's alternator will charge the Battery or plug into a 110V hookup or start your Generator, so the Battery Charger, built into your Power Converter or Inverter (o) will charge Battery.
5. When 110V power is supplied to the van, the Auxiliary Battery will only have power drawn from it if the total 12V power usage exceeds the 12V power supplied by the Converter.
6. A Battery Separator, included for all vans, will prevent any drain from your van's starting battery.
7. Note – Do not "fast charge" battery with an "outside" battery charger while electric Refrigerator is turned on.

**AUXILIARY BATTERY PERFORMANCE**

1. AGM Batteries are sealed - there is no maintenance.
2. The amp-hour value of a battery refers to the number of amps a battery will deliver over a specified period of time before the battery has discharged to a useless level – 10.5 volts.
3. Ambient temperature has a strong effect on battery performance. The "performance" of the 100 amp AGM is rated at around 80°F. At higher temperatures the Battery has a greater capacity. At lower ambient temperature the amp-hour performance is lower. However, at higher temperatures the refrigerator will cycle more often, using more amps. At lower temperatures the cycle time will be less.

**HOW LONG WILL AN AGM BATTERY LAST?**

1. An AGM battery usually lasts 3 to 5 years. Sometimes only 2 years. Occasionally up to 8 years.
2. There are many variables. Extra low or high ambient temperatures will shorten the life. Leaving the Auxiliary battery fully discharged for more than 48 hours will also shorten the life.
3. To help lengthen the life, only discharge the battery 50% or about 12.2 volts. Then fully charge within 48 hours. When storing the Sportsmobile, disconnect the battery to prevent any drain or keep the van connected to shore power. Voltage of a fully charged battery is 12.8 volts.

**REPLACEMENT**

1. Sportsmobile can install a new one for you or ship one UPS.
2. Or look online. Search for AGM Deep Cycle, Group 27 or 4D for the larger one. Many battery retailers have these batteries.

**REPLACING THE AUXILIARY BATTERY:**

Ensure that the inverter is disconnected prior to disconnecting the auxiliary battery.  
 Disconnect 110V hook-ups.  
 Always remove ground wire first and reinstall last.

**4D AGM BATTERY ACCESS**

1. The much larger 4D AGM battery is usually located under the van on the passenger side. The battery is heavy, it weights 130 lbs and the support tray is 15 lbs. If it needs to be replaced we recommend you have Sportsmobile or a service center to do it.
2. Remove wire clamp under van to rear of battery fastened under the floor of the van.
3. With a floor jack under battery remove the four 5/8" bolts at each of the side, bottom corners. Lower battery then remove from jack.
4. Pull battery out from under van (wire is long enough), remove (black) ground wire first. Then remove (red) hot wire. Inspect or remove and replace battery. Reinstall (red) hot wire first then (black) ground wire. Lift up on jack and raise into place. Install the four 5/8" bolts then the wire clamp.

**WHY WE USE AGM BATTERIES**

1. They are more expensive; however we feel it's well worth it to the customer...
2. According to the manufacturer the latest and most advanced battery technology is Advanced AGM, which was developed to provide increased safety, efficiency, and durability over all existing battery types. This is the same type battery used in military aircraft.
3. In advanced AGM batteries the acid is absorbed into a very fine glass mat that is never free to slosh around. The plates are kept only "moist" with electrolyte so gas recombination is more efficient. (99% AGM). Since they are sealed you will never have to check them.
4. Since the AGM material has an extremely low electrical resistance, the battery delivers much higher power and efficiency.
5. AGM's can be charged much faster, about 20%, if needed and also deliver higher power when required. Owners using high output alternators, operating inverter banks, or relying on solar panels can benefit significantly when using AGM batteries.
6. AGM batteries offer exceptional life cycles. All batteries eventually die. When cycled at between 25 and 40 percent depth of discharge (recommended deep cycle use) AGM batteries will normally easily outlast lead acid and gelled acid CE designs.
7. According to the manufacturer of AGM batteries, they are the safest available. They are the only marine type batteries to pass the rigid Military Specifications for non-gassing even during severe overcharging.

**BATTERY QUESTIONS? [www.eastpenn-deka.com](http://www.eastpenn-deka.com)**



# Deka AGM Series (Absorbed Glass Mat) for longer and safer battery operation

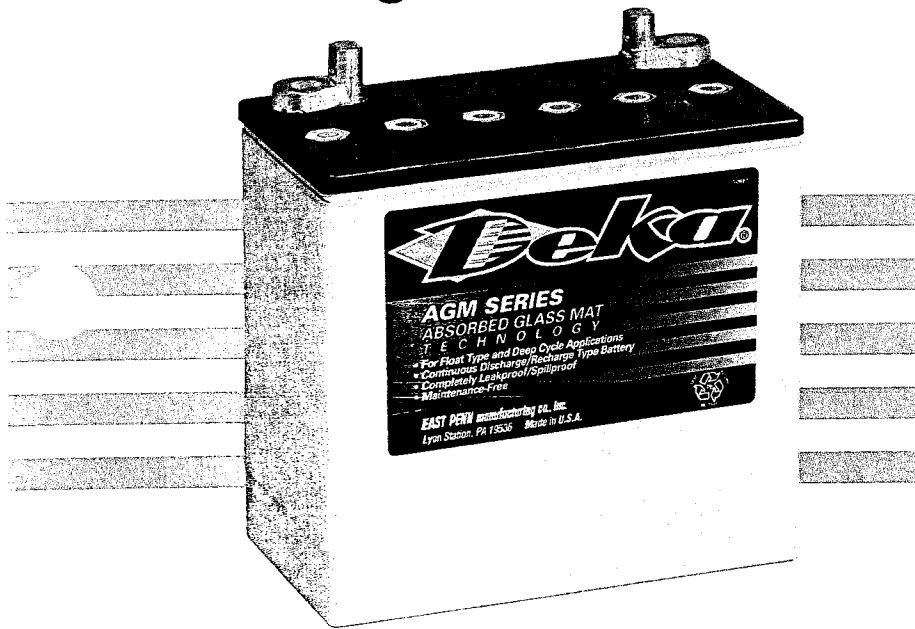

Deka's AGM (Absorbed Glass Mat) Series uses a special absorbed electrolyte technology that is superior to conventional lead-acid batteries. This completely sealed valve-regulated battery line eliminates gas emissions and acid leakage for longer and safer battery operation.

### How AGM Works

Unlike conventional "flooded" lead-acid batteries, AGM sealed valve-regulated technology eliminates the need to add water because the oxygen and hydrogen gases react to maintain the necessary amounts of moisture. Highly porous microfiber separators wrapped around the positive plates completely absorb and trap the electrolyte, so there is no excess to spill or leak out of the battery. Oxygen formed from the positive plates during charging passes horizontally through the separator pores to the negative plates, where it reacts with hydrogen and changes back to water to replenish the electrolyte.

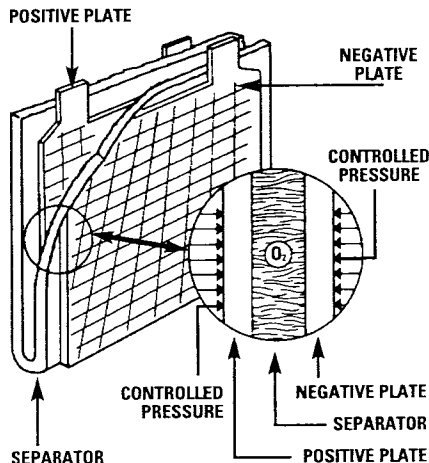

Oxygen diffuses through the horizontal separator pores to the negative plate as this is the only available path.



QUALITY SYSTEM CERTIFIED TO ISO 9001 ISO/TS 16949 ISO 14001

**AGM Features** – The extremely efficient design includes several unique features.

- Specially-engineered safety relief valve system effectively **controls critical internal gas pressure**, preventing capacity loss from excessive gas seepage. This one-way valve also prevents outside air from entering the battery—a common cause of failure in most sealed valve-regulated battery designs.
- Fine microfiber **glass separators are highly porous** to hold electrolyte more efficiently and have extremely low electrical resistance for higher capacity.
- Power path grids are **computer-cast and pasted** to uniform thickness, allowing for the exact degree of compression needed for optimum oxygen flow between the plates and separators. (Plates compressed too tightly will impede oxygen flow, while plates packed too loosely allow valuable oxygen to escape to the top of the battery. Both conditions seriously impair performance and shorten battery life.)
- Exclusive **individual tank formed plates** provide the highest quality and most consistent performance.
- Most AGM batteries are rated non-spillable by ICAO (International Commercial Airline Organization), IATA (International Airline Transport Association) and DOT (Department of Transportation) definitions.

**AGM Benefits** – The AGM Series offers all the advantages of conventional "flooded" batteries without the disadvantages.

- **Maintenance-free** construction eliminates the need to add water.
- **Completely sealed** valve-regulated design eliminates acid spills and terminal corrosion.
- **Safer operation** substantially minimizes chance of acid spray, fumes and explosion hazards when charged correctly.
- **Flexible design** can be installed in almost any position. (However, upside-down installation is not recommended.)
- **State-of-charge easily determined** by open circuit voltage.
- **Lower electrical resistance** provides higher discharge rates.
- **High freeze-resistance** offers longer battery life.
- **Resists vibration** damage for longer operating time.
- **Lightweight construction** for easy installation.
- **Requires less charging time** than conventional batteries.

"POWERED FOR PERFORMANCE"™

## EAST PENN manufacturing co., inc.

Lyon Station, PA 19536-0147 • Phone: 610-682-6361 • Fax: 610-682-4781  
Order Department Hotline: 610-682-4231  
www.dekabatteries.com • E-mail: eastpenn@eastpenn-deka.com

DISTRIBUTED BY:

ABSORBED GLASS MAT SERIES



# ABSORBED GLASS MAT SERIES

GROUP NO.	PART NO.	FOOT NOTES	STANDARD/OPTIONAL TERMINAL (FOOTNOTE)	MINUTES DISCHARGED AT*					DISCHARGE AMPS PER 12-VOLT BATTERY TO 1.75 VPC @ 80°F (27°C)*							
				75 AMPS	50 AMPS	25 AMPS	15 AMPS	8 AMPS	5 AMPS	5 MINS.	10 MINS.	15 MINS.	20 MINS.	30 MINS.	60 MINS.	90 MINS.
<b>STARTING OR DEEP-CYCLE - EV - TROLLING MOTOR - WHEELCHAIR</b>																
U1	8AU1	38,39	Y / NA	10	20	54	98	200	340	110	75	60	50	39	23	16
	8AU1H	17,38,39	Y / NA	10	20	54	98	200	340	110	75	60	50	39	23	16
22NF	8A22NF	38,39	G / NA	22	40	102	180	365	620	160	120	95	80	62	35.5	28
24	8A24	17,38,39	G / NA	35	60	150	280	550	900	220	165	130	110	85	50.5	36
	8A24NH	38,39	G / B	35	60	150	280	550	900	220	165	130	110	85	50.5	36
27	8A27	17,38,39	G / B	43	75	185	330	640	1080	270	200	153	130	98	59	44
31	8A31	17,38	X	53	87.4	200	348	706	1265	305	226	174	147	114	68.2	49.0
	8A31DT	17,38	SX / NA	53	87.4	200	348	706	1265	305	226	174	147	114	68.2	49.0
4D	8A4D	17	S	106	180	413	745	1512	2507	508	408	318	266	200	115	85
8D	8A8D	17	S	138	230	517	953	1874	3040	600	475	386	325	256	151	106
GC2	8AGC2		G	94	171	409	718	1409	2304	—	—	—	—	—	—	—

GROUP NO.	PART NO.	CCA @ 0°F (-18°C)	RES. CAP.	VOLTS	AMPERE HOUR CAPACITY*					APPROX. WEIGHT LBS. (KGS.)	MAXIMUM OVERALL DIMENSIONS INCHES (MM)			STANDARD/OPTIONAL TERMINALS
					20 HR.	8 HR.	6 HR.	3 HR.	1 HR.		LENGTH	WIDTH	HEIGHT	
<b>STARTING OR DEEP-CYCLE - EV - TROLLING MOTOR - WHEELCHAIR</b>														
U1	8AU1	200	48	12	32.0	29.5	28.3	26.5	23.0	24.0 (10.9)	7% (197)	5% (130)	7% (184)	
	8AU1H	200	48	12	32.0	29.5	28.3	26.5	23.0	24.0 (10.9)	8% (211)	5% (130)	7% (184)	
22NF	8A22NF	280	90	12	55.0	50.0	49.0	45.0	35.5	38.5 (17.5)	9% (238)	5% (140)	9% (235)	
24	8A24	470	140	12	79.0	72.0	70.5	65.0	50.5	53.0 (24.0)	10% (276)	6% (171)	9% (251)	
	8A24NH	470	140	12	79.0	72.0	70.5	65.0	50.5	53.0 (24.0)	10% (260)	6% (171)	9% (251)	
27	8A27	580	175	12	92.0	84.0	82.5	75.0	59.0	63.0 (28.6)	12% (324)	6% (171)	9% (251)	
31	8A31	650	190	12	105.0	90.0	87.4	81.5	68.2	69.0 (31.3)	12% (329)	6% (171)	9% (238)	
	8A31DT	650	190	12	105.0	90.0	87.4	81.5	68.2	69.0 (31.3)	12% (329)	6% (171)	9% (238)	
4D	8A4D	1110	380	12	198.2	176.0	167.4	150.0	115.0	129.0 (58.5)	20% (527)	8% (216)	10 (254)	
8D	8A8D	1350	480	12	245.0	212.0	202.8	182.1	151.1	158.0 (71.7)	20% (527)	11 (279)	10 (254)	
GC2	8AGC2	690	380	6	187.0	173.7	167.8	144.8	102.6	69.5 (32.0)	10% (260)	7% (181)	10% (276)	

**FOOTNOTES:**

- B - Flag terminal w/ 3/8" diameter hole
- G - Offset post w/ horizontal hole, stainless steel 5/16" bolt & hex nut
- S - SAE "automotive type" post
- X - 3/8" x 16 stainless steel stud posts
- Y - Small L terminals with round holes

Warranty void if opened or improperly charged. Caution: Constant under- or overcharging will damage any battery and shorten its life. Use a good constant potential, voltage-regulated charger. For 12-volt batteries, charge to at least 14.4 volts but no more than 14.6 volts at 68°F (20°C). For 6-volt batteries, charge to at least 7.2 volts but not more than 7.3 volts at 68°F (20°C). Do not charge in a sealed container. The SAT Series has more capacity at high discharge rates than conventional deep cycle batteries.

- 17 - Includes handles
- 38 - "Non-Spillable" defined by DOT (Department of Transportation) definition
- 39 - "Non-Spillable" defined by ICAO (International Commercial Airline Organization) and IATA (International Airline Transportation Association) definitions

\* Nominal

All batteries are manufactured in polypropylene cases.  
All AGM batteries have a grey case and a black cover.

**Potential Applications of AGM**

**Starting, Lighting and Ignition**  
Cars • Trucks • Marine • Snowmobiles  
Lawn & Garden Tractors

**Traction**  
Wheelchairs • Floor Sweepers • Guided Vehicles  
Small Fork Lifts • Trolling Motors

**Industrial**  
Cable TV • Emergency Lighting • Exit Lighting  
Alarm and Security Systems • PBX Systems • Utility Control  
Switching Equipment • Medical Equipment  
Recreational Vehicles • Electronic Cash Registers

**Portable Devices**  
Construction Equipment • Portable Pumps and Generators  
Portable Test and Measuring Equipment  
Portable Tools • Mobile TV, VCR, VTR

**Constant Voltage vs. Temperature**

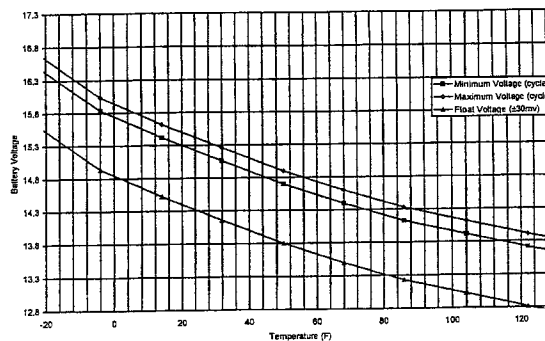

Shown is the constant charging voltage in relation to the ambient temperature for cyclic and float use.

**Capacity vs. Operating Temperature**

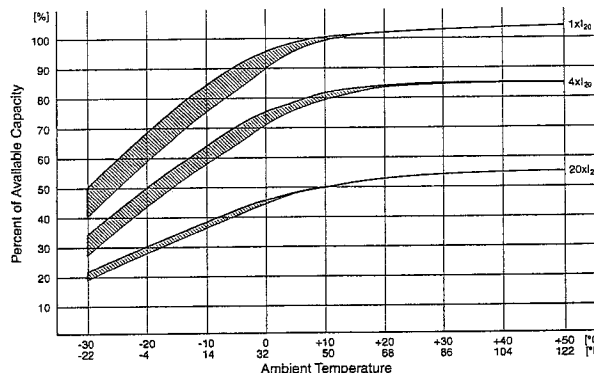

Shown are the changes in capacity for a wider ambient temperature range, giving the available capacity as a percentage of the rated capacity at different ambient temperatures, for three different load examples, with uninterrupted discharge to the appropriate discharge cut-off voltage. The values for the upper edge of the curve were obtained from charging at an ambient temperature of +20°C (68°F), with a voltage limit of 2.3 V/cell. For the lower edge, charging was carried out at the specified ambient temperature. The curves show the behavior of the battery after a number of cycles.

## **DEKA BATTERY WARRANTY**

**East Penn Manufacturing Co., Inc. warrants its 8A4D with the T975 terminals to be free from defect in material and or workmanship (not merely discharged) for a period of 24 months. If the battery is found to be factory defective within the first 12 months from the purchase of your Sportsmobile, it will be replaced with a similar product at no charge to the customer. (Installation charges, towing charges, etc. are not covered by the manufacturer warranty. The remaining 12 months will be prorated at the current retail price. Proof of purchase is required.**

**WEB SITE: [www.dekabatteries.com](http://www.dekabatteries.com)**

**800 NUMBER 800 237-6126**

**HOW TO CONSERVE BATTERY POWER**

1. **Refrigerator** – First, open the door as seldom as you can as the cold air “falls” out. It will also help to keep the Refrigerator full. If only partially full, you can wad up newspaper to fill the void. This way when you do open the door, little cold air will be lost. Also keep the thermostat set as low as you can.
2. **Lights** – Use a lot of amps. Use them frugally. Florescent lights use less amps and also burn cooler.
3. **Detectors** – The 2 detectors pull .4 amps per hour or 9.6 amps in 24 hours. If you are not going to be in your Sportsmobile for an extended period of time, you can pull the 3 amp fuse from the 12V Distribution Panel.  
Warning – replace the fuse as soon as you re-enter the Sportsmobile. It is not recommended that a separate switch be wired to the detectors.
4. **TV/VCR** – will use 6 amps per hour when being used on 12 volt power. The TV can use up to .2 amps per hour even when it is turned “off”. Unplug TV to eliminate this extra power drain or turn TV rocker switch “off”.
5. **Water Pump** – Draws 4 amps, only when running. When connected to city water turn pump off.
6. **Radio Switch (N/A Sprinter)** – The van in-dash radio can operate with the ignition “off” whenever the radio switch is set to “Auxiliary” Battery. Turn the radio switch back to “Main” Battery when not using the radio. The van starting battery can discharge if radio switch is set to “Auxiliary” Battery. About 3 amps per hour usage on Auxiliary Battery and 1 amp per hour on van starting battery.

**HOW LONG TO CHARGE?** That's a hard question to answer. There are many variables.

**DRIVING – CHARGING WITH THE “VAN'S ALTERNATOR”**

1. The van's alternator will only charge the Auxiliary Battery to 85-90% of its capacity. The amount of time it takes varies. 12.8 volts (with charge source & load removed) is a fully charged battery.
2. 12.2 volts (with charge source & load removed) is a 50% discharged battery. The life of the battery is shortened if repeatedly discharged below 12.2 volts.
3. Idle the van engine (Aux. High Idle feature on diesels) without the A/C or lights on to maximize the charge going to the auxiliary battery.
4. As we stated in the beginning, there are a lot of variables to consider.
5. If you are driving with only the van's ignition and fuel system drawing amps from the van's starting battery, you could charge the Battery in around two hours or so.
6. If you drive your Sportsmobile every day for only 30 minutes or so, and you leave your Refrigerator on, we suggest you connect the 110V power when you are home, every other day or so. This will assure that the Auxiliary Battery will be kept fully charged. Prior to going on a trip, we suggest you start with a fully charged Battery.

**WHILE PARKED – AND CONNECTED TO “110V POWER”**

1. Again, there are many variables.
2. The Power Converter/Battery Charger has a maximum of 65 amps per hour. Or 100 amps with Inverter (O).
3. All of the Converter/Charger output power could be used – if you have the Starcool A/C (N/A with Sprinter) on high, and other items on, such as a number of Lights, TV, Fan, etc. It would take 12 hours or so to fully charge the Auxiliary Battery. If you did not have the A/C on, it will be less. The Starcool compressor will be running on 110V. The Starcool condenser and blower fans will be on 12V.

**AT A CAMPSITE WITHOUT 110V HOOKUPS, YOUR AUXILIARY BATTERY IS GETTING LOW AND YOU WANT TO STAY ANOTHER NIGHT?**

Idle your van's engine 90 minutes or so – without the A/C or Lights off, or take a 30 minute drive. This should charge the Auxiliary Battery enough to be able to operate your Refrigerator over night.

**CHECKLIST — 12V SYSTEM**

To prevent draining your 12V Auxiliary Battery(s) when you are not driving your Sportsmobile for a while or storing it:

1. Keep van connected to a 110V hookup when possible
2. **TURN OFF**
  - All Lights
  - Refrigerator
  - Water Pump
  - Fans
  - Carbon Monoxide & Propane detectors — Pull 3 amp fuses.

**Also,**

- Attic Fan, "deluxe" model (O), turn switch to "Off."
- Voltmeter — Pull from 12V plug.
- Radio Switch (O) — Switch to "Van Battery" position (N/A Sprinter).
- Inverter (O) — Switch to "Charge Only."
- Dodge Sprinter — Propane remote switch "Off."

**WARNING — Replace all "detector" fuses prior to driving.**

2. Or — you can disconnect the negative terminal wire from your Auxiliary Battery(s). This will ensure there will be no 12V drain from any source. If you disconnect the battery, it will not be necessary to do any of the above.
3. Or — if you have an auxiliary battery disconnect switch (O) turn the switch off.

(O) Optional Items

**GENERAL**

If you should experience a problem with your battery or 12V system, the following will help you trace it down. At some point you may not feel comfortable in taking the next step in locating the problem. We suggest you then have one of the Sportsmobile plants take over or call Sportsmobile prior to taking to an RV service center.

**A. PROBLEM: LIGHTS ARE DIM - WHEN "CONNECTED" TO A 110V HOOKUP.**

- \_\_\_ Verify 110V power is present.
- \_\_\_ Check that circuit breakers are "on".
- \_\_\_ Check reset button on GFI outlet. Push to test. Push to restart.

If above is okay proceed to "B"

**B. PROBLEM: EXTRA BATTERY DOES NOT SUPPLY POWER LONG ENOUGH - WHEN "NOT" CONNECTED TO A 110V HOOKUP.**

- \_\_\_ See the extra battery sheet for access and other information.

If above is okay proceed to "C"

**C. POWER CONVERTER / CHARGER OKAY?**

- \_\_\_ With Sportsmobile connected to 110V hookup and van engine "not" running, battery analyzer should have yellow or yellow and green light on - 13.2 volts or more.

**VAN ENGINE "OFF" 110 VOLT POWER PRESENT**

- Check voltage at Extra Battery, Reading should be between 12.8 and 14.8 volts

- If below 12.8 volts
  - Check output voltage at Converter/Charger terminals.
  - If below 12.8 volts, verify 110 volt power is present at Converter/ Charger, check GFI outlet, reset.
  - Check fuse on Converter/Charger. If blown, replace.
  - If voltage is still below 12.8 volts at Converter/ Charger terminals, replace Converter/ Charger
- If above 15.8 volts, replace Converter/Charger
- If above 12.8 volts, check wires and connections to auxiliary battery

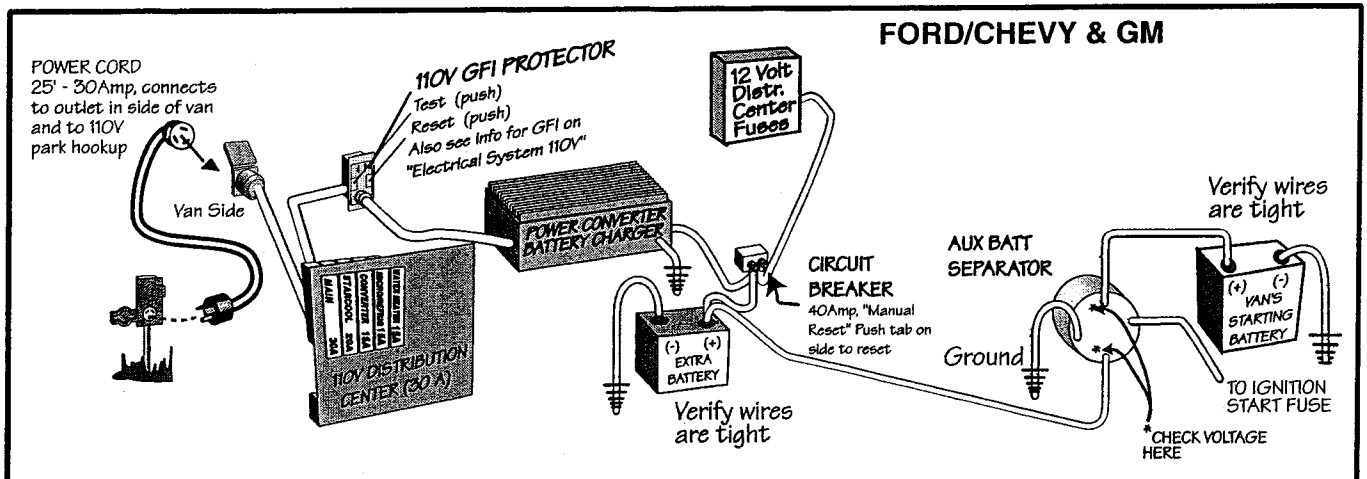

**D. AUXILIARY BATTERY OKAY?** Use voltmeter supplied by Sportsmobile

This will test for "voltage."

- \_\_\_ When van's engine is not running and auxiliary battery is at rest
- \_\_\_ When connected to a 110V hookup or running a generator.
- \_\_\_ also when van is running, checks alternator charging.

SIGN	LED LAMP	DIGITAL READOUT 12V		INDICATION	CONDITION
		LOW	HIGH		
NO SIGN	<input type="checkbox"/> LOW (Red) <input type="checkbox"/> MED (Yellow) <input type="checkbox"/> HIGH (Green)	Below 11.8V		POOR	Examine storage battery charging and electric system.
<input type="checkbox"/>	<input type="checkbox"/> LOW (Red) <input type="checkbox"/> MED (Yellow) <input type="checkbox"/> HIGH (Green)	Below 12.5V		NORMAL	Normal
<input type="checkbox"/>	<input type="checkbox"/> LOW (Red) <input type="checkbox"/> MED (Yellow) <input type="checkbox"/> HIGH (Green)	Below 16.0V		FULL	Charging of battery is full.

LED ON     LED OFF



**TO CHECK AUXILIARY BATTERY:**

- \_\_\_ Plug voltmeter into a 12V outlet. Check auxiliary battery status.
- \_\_\_ Van engine off.
- \_\_\_ Voltmeter should read 12.2 to 12.8
- \_\_\_ If lower than 12.2, charge auxiliary battery for 12 hours.
- \_\_\_ Let rest for 1 hour.
- \_\_\_ Check again.
- \_\_\_ If still below 12.2, have battery checked.

The only way to check Sportsmobile AGM sealed battery is to have a load test performed. This can be done at Sportsmobile or any qualified service center. If test bad, replace.

**E. TO CHECK CHARGING SYSTEM**

- \_\_\_ Van engine running. Plug voltmeter into a Sportsmobile 12V outlet.
- \_\_\_ Voltage should be 13.2 to 15 volts max.
- \_\_\_ If voltage is less than 13.2, proceed to "F"

**F. AUXILIARY BATTERY SEPARATOR OK? See drawing, page 36.**

- \_\_\_ You will now need a Multimeter for this test — available at Wal-Mart, Radio Shack and most auto supply stores for as little as \$10.
- \_\_\_ Van engine off. Check fuse located close to Separator. If blown fuse, replace.
- \_\_\_ Start Van. with voltmeter plugged into a Sportsmobile 12V outlet. If voltage is between 13.2 and 15.2, it's fixed.
- \_\_\_ Van engine off. Check white ground wire. Follow Multimeter directions.
- \_\_\_ If ground wire not grounded — ground it.
- \_\_\_ Start engine. With voltmeter plugged into 12V outlet and reading is 13.2 or more — it's fixed. If still under 13.2 proceed.
- \_\_\_ Check Separator main terminals with the van running.
- \_\_\_ If the one marked "Auxiliary" has less than 12.8 volts and starting battery terminal 13.2 or more, replace Separator. If neither terminal has 12.8 volts or more, have approved Sprinter dealer check charging system.



**Typical 12/110V Requirements**

	12V AMPS/HR	110V AMPS/HR	RUNNING WATTS	REMARKS
<b>12 &amp; 110v</b>				
(1) Refrig. A - 3CF, Elect	2.5 (1)		30	
B - 4CF, Elect	2.8 (1)	.2	34	
S - 7CF, Elect	3.2 (1)	.4	38.5	Available On Sprinter Only.
D - 4CF, Elect/prop	12 (1)	13	132/1560	12/110v & Propane Refr. Use Lots Of Battery Power.
tv - Typical Model, 9"	6 (6)	.6	70	(6) TV Can Use .2 Amp Per Hour Even When
Flat Panel, 15"	9.2 (6)	.9	110	Switched "Off." Unplug TV To Eliminate Drain.

12v	12V AMPS/HR	110V AMPS/HR	RUNNING WATTS	REMARKS
Water Pump	4 (1)		48	
Light Swivel - (One Bulb)	1.5		18	
Fluorescent - (2 Bulb)	1.9		16	
Fan	1.7		21	
Attic Fan - On Low	1.9		23	
Medium	2.3		28	
High	3		36	N/A Sprinter
Radio, Dash Switch	3		36	
Lp Detector	.2		2.4	
Co Detector	.2		2.4	

110v	12V AMPS/HR	110V AMPS/HR	RUNNING WATTS	REMARKS
A/C Starcool (On High)	24(8)(1)	(7) 16.2	1,944	(7) 110 Volt Amps Are Used Only When Van Engine Is Not Running.
A/C Starcool w/gen.(O)	24(8)(1)	(7) 13.2	1,584	(8) For 12v Blower Fan And Condenser Fan
Roof A/C 12,500 Btu	(1)	12.9	1,425	
Microwave		.8	1,000	
Water Heater, 110v	(1)	12.9	1,500	
Hair Dryer		3-4	350-500	Depending On 12 Volt Load
Electric Blanket	(1)	.5-1.5	50-200	
Computer		.5	30-50	
Power Converter		0-4	0-500	

Note: Some Items Shown Are Options.

**(1) These Items Will Cycle On And Off As Power Is Required. Amp X Volts = Watts**

**GENERATOR GAS**, Onan 2.8k - Provides 2,800 Watts Of Power. The Starcool A/C Uses 1,584 Watts. This Will Leave 1,216 Watts For Other 110v Items. A Microwave Requires 1000 Watts, For 600 Watts Cooking Power.

**GENERATOR PROPANE**, 2.5k - Provides 2,500 Watts Of Power.

**POWER CONVERTER**, 65 A - When You Have 110v Hookup The Converter Will Supply Up To 65 Amps Of 12v Power.

**INVERTER**, 2,000 watts 110V. 100A, 12V charger.

**SOLAR PANELS**

Solar panels collect the sun's energy and store it in your auxiliary battery/batteries. Note – one auxiliary battery is standard with Sportsmobile's Standard Equipment Package. We recommend adding a second one, especially if you add more solar panels. The energy storage from solar panels is the same as when you run your van's engine to have the van's alternator charge your batteries. Or, when you are connected to a 110V hook-up or generator, your power converter/battery charger will keep your auxiliary battery charged. Keep the panels clean.

**EXAMPLE**

- One Kyocera 130 watt solar panel will produce a max of 7 amps per hour of 12 volt power.
- If you have 8 hours of sunlight, you will be able to put a max of 56 amp hours into your battery system.
- A 4 CF refrigerator uses 2.8 amps per hour when it's running. Most refrigerators will run for about 16 Hours (or 65%) in a 24 Hour period. Of course, there are variables. 16 hrs x 2.8 amps = 49 amps. This is average daily amp consumption of the refrigerator.
- If you put in 56 amps per day in the auxiliary battery and the refrigerator uses about 49 amps, you will have a positive charge of about 7 amps over 24 hours.
- Most customers like the security of a second solar panel, which will provide additional amps for 12V lights, water pump, TV, etc.
- Four solar panels can be installed on some tops – depending on the length, or if a roof A/C, attic fan, etc. is also installed on top.

**Keep in mind:** When driving or plugged into a 110 volt hook-up or running generator, your solar panel is not charging the battery. However, your van's alternator or power converter/battery charger is. The panels are for recharging when you do not have a 110 volt hook-up or generator. In shade, panels are not producing much power, if any.

**SOLAR CONTROLLER**

Sportsmobile uses the Blue Sky Solar Boost 2000E Controller. It costs more than other controllers, but it's patented cutting-edge technology increases charge current up to 37%, compared to conventional controllers. Plus providing other benefits described below.

According to the manufacturers patented MPPT technology used in Blue Sky Solar Boost controllers operates in a very different fashion from conventional controllers. The Solar Boost controller continually calculates the module's maximum power voltage, in this case 17 volts. It then operates the module at its maximum power voltage to extract maximum power. The higher power extracted from the module is then provided to the battery in the form of increased charge current. In conditions where extra PV power is not available, Solar Boost controllers will operate as a conventional controller with very low voltage drop.

The actual charge current increase you will see varies primarily with module temperature and battery voltage. In comfortable temperatures, current increase typically varies between 10 to 25%, with 30% or more easily achieved with a discharged battery and cooler temperatures.

A built-in LCD digital display monitors solar charge performance. The display shows battery voltage, solar panel current and output charge current. You can actually see current boost working by knowing the difference between solar panel current and output charge current. A charge status LED indicates the present charge mode, and shows when the battery has become fully charged.

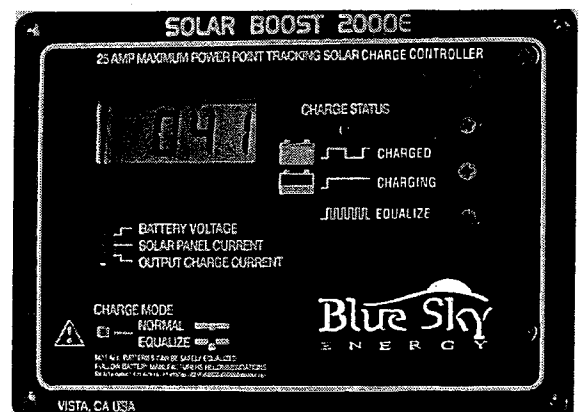

**PROPANE DETECTOR**

**MODEL GS/3** Manufactured by Electro Systems. Email: info@es-web.com

**OPERATION**

1. When you connect power to your new detector it goes through a start up cycle. The green LED (marked "Power") comes on. The red LED (marked "Alarm") and horn will pulse for approximately 5 seconds until the sensor is warmed up.
2. If no fumes are detected, the red LED and horn stops and the green LED remains on, indicating the detector is active.
3. The detector can be tested by injecting gas (no flame) from a butane lighter for 5 seconds into the lower grill. This test should be done monthly to ensure proper operation of the detector.

**IF FUMES ARE PRESENT**

1. If fumes are present at start-up, the horn and red LED will continue to pulse - from 60 pulses/minute for concentrations lower than 25% of the lower explosive level, to 80 pulses/minute for higher concentrations.
2. If fumes are detected at any time after start-up the horn and red LED will start to pulse. If this occurs, immediately shut off the propane supply and ventilate the area.
3. Avoid using any source of ignition, including electric switches, electric motors, pilot lights or other open flames. When the fumes have dissipated, the horn will stop and the red LED will turn off, indicating a safe atmosphere.
4. The leak should be corrected before resuming operation of the propane system.
5. A continuous tone indicates a short in the electronics and a single pulse every 10 seconds indicates a faulty sensor. If either of these signals occur, return the detector to your dealer for repair or warranty replacement.

**FALSE ALARM**

1. The presence of other organic vapors, such as paint fumes, solvents or hair spray can trigger a false alarm.

**DO NOT BLOCK AIR CIRCULATION IN THE AREAS THE DETECTORS ARE LOCATED.**

**CHECK THE DETECTORS MONTHLY.**

**REPLACE THE BATTERIES EVERY SIX MONTHS.**

---

**CO DETECTOR** See Manufacturer's literature

---

**RADIO POWER SELECTOR SWITCH (N/A Sprinter)**

1. The purpose of the selector switch is to allow you to have the radio operating while parked and the ignition is "off." By being able to switch back to the original "Van" battery power source, you will not have to turn the radio "off" each time you turn your ignition "off." Turn radio switch back to "Van" battery to prevent discharge of your van's starting battery.

**RADIO SWITCH OPERATION**

1. Selector switch allows the radio to receive power from either the van's starting battery or the extra battery

**SGW — RADIO DOES NOT OPERATE**

1. If radio does not operate, check the fuses at factory fuse block and 12V distribution center. Check for 12V power to fuse.
2. If fuse is blown, replace with same size fuse.
3. If new fuse blows, have system checked by a qualified technician.

**NOTE — Switch should be set to "Van" battery when not using radio while parked. Van's starting battery will discharge if switch is on "Extra Battery" too long.**

- ✓ Sprinter
- ✓ Ford & Chevy/GM

# 110V - ELECTRICAL SYSTEM

# 50

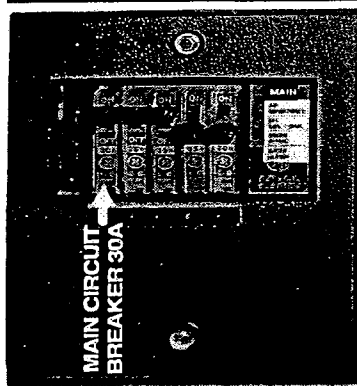
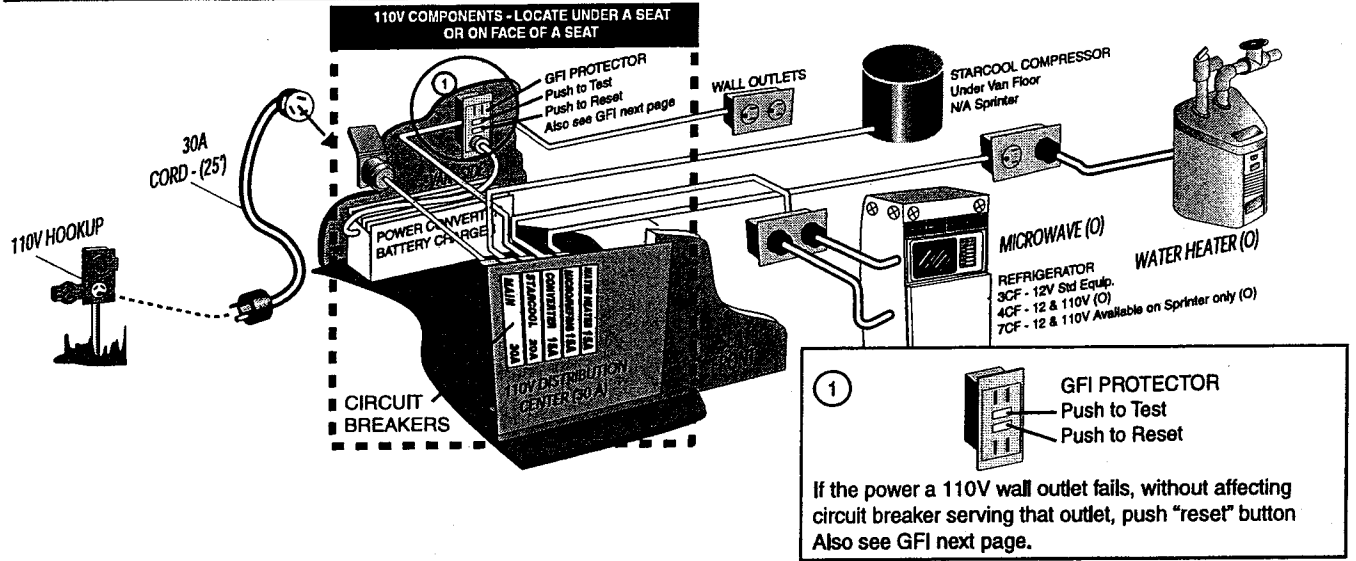

**110V DISTRIBUTION PANEL. NO 110V POWER IN VAN?**  
Flip main breaker on and off.

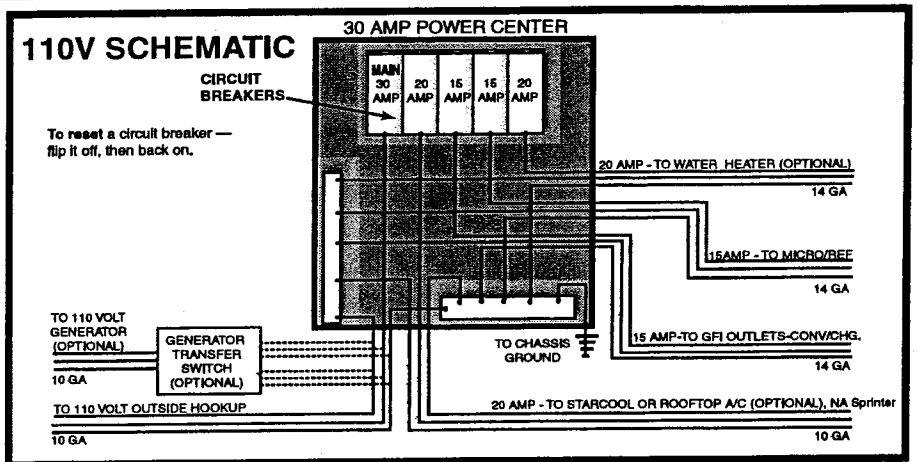

## GENERATOR — WIRED INTO 110V SYSTEM

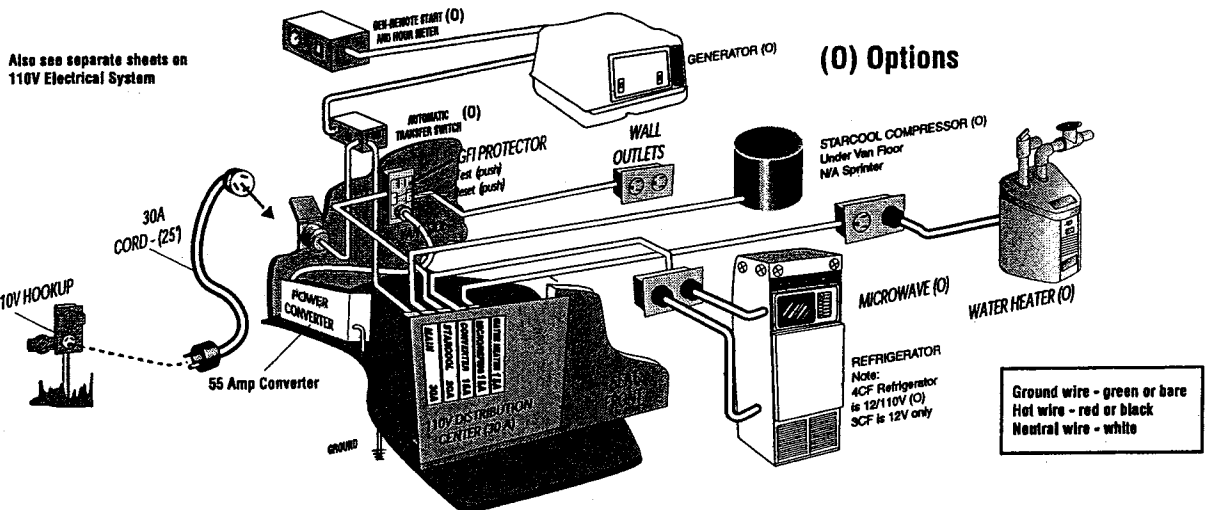

**What Appliances Require 110V?**

For 110V power you must have a 100V park hookup or Generator (O) or Inverter (O)

- Microwave (O)
- Air Conditioner (O)
- Hot Water Heater, 110V (O)
- Portable Heater (O)
- Plus other 110V items such as electric blankets, tools, etc.

**HOW TO CONNECT TO PARK'S 110V HOOKUP**

1. Flip main 30A, 110V breaker off if in your Sportsmobile.
2. Connect your 30A power cord to the park 110V hookup, and to the van. Check that park 110V hookup breaker is on.
3. Flip main, 30A, 110V breaker on in your Sportsmobile. Note: if you are operating from a generator, wait 5 minutes before you flip the main breaker on.
4. You now have 110V power to your 110V appliances and wall outlets.
5. If you use the power cord adapter, your available power will be reduced from 30A to 15A. This adapter permits you to connect to a 15A park hookup.  
The use of the A/C or appliances may be restricted. DO NOT use extension cord.

1. To reset a tripped circuit breaker, flip it off, then back on.
2. NOT SURE IF YOU HAVE 110V POWER IN THE VAN? Use a nightlight in a 110V outlet. If it doesn't light up check the 30A breaker switch and your GFI protector, see below.

**INVERTER** If you have this option you must turn it on to supply power from the Auxiliary Battery.

**ALL 110V appliances are protected by circuit breakers.**

1. It is possible to trip the 30 amp main breaker if all the appliances are operating simultaneously. If this occurs, turn off any appliance you don't need, then reset the Main 30A breaker.
2. If individual circuit breakers trip, reset. If breaker continues to trip, have a qualified electrician check the appliance or breaker.

**GFI PROTECTOR**

1. To protect you from line to ground electric hazards, a GFI Interrupting Receptacle has been installed. It protects wall outlets that are exposed. The concealed wall outlets for such items as the Refrigerator are not GFI protected.
2. If the power at a 110V wall outlet fails, without affecting the circuit breaker serving that outlet, push the "reset" button to restore power.
3. If the GFI Interrupter cannot be reset, disconnect the appliance connected to it and then reset. Repair any defective appliance before further use. If the receptacle will not reset when there are no appliances connected to it, confirm 110 volt power is present. Have a qualified electrician check the GFI outlet.
4. The GFI Interrupter must be tested at least once every month. 110V power must be present to properly test.
  - A. Push "test" button. The "reset" button should pop up 1/16" minimum, from flush position, which indicates that power to the protected circuit has been discontinued.
  - B. If the "RESET" button does not pop up when the test button is pushed, a loss of ground fault-protection is indicated, or you do not have 110 volt power present.  
**WARNING. DO NOT USE.** Call a qualified electrician.
5. This ground fault circuit interrupting receptacle is designed to help protect people from the hazards of line to ground electrical faults. It does not prevent electric shock, but limits the shock time, This protection is afforded to people using tools or appliances operating from the receptacle.
6. Outside Sportsmobile 110V outlet — this option is also protected by GFI interrupter.

### DIFFERENCE BETWEEN ...

- **“CONVERTERS”** Convert 110V to 12V when you are connected to a 110V hook-up. 12V power will power your 12V lights, TV, Fan, etc. and charge your Auxiliary Battery. A converter is standard equipment. **“INVERTERS”** Convert 12V battery power to 110V to power microwave (O), hot water heater (O), computer, hand tools, etc. when connected to shore power, they will charge your Auxiliary Battery. It will not power the Starcool A/C (Option for Ford/Chevy) (O) Optional

### GENERAL — XANTREX OR TRIPPLITE 2000 INVERTERS

- When you are connected to a 110V outside hook-up, the converter with the built in battery charger will charge your batteries without overcharging and will maintain the charge.
- When an inverter is ordered the Std. Equip. Pkg. power Converter/Battery charger is deleted. Credit is allowed for this in the price of the Inverter.

### SGW (SOMETHING GONE WRONG)

- No power. A The Zantrex or Tripplite Inverter has a low battery cut-off feature which prevents the Inverter from operating if the 12V auxiliary battery voltage is too low.  
 B If the Inverter needs to be operated before the auxiliary batteries are recharged, you can run the van engine while operating the Inverter.

STILL HAVE A PROBLEM? Please call Xantrex Customer Service 800-670-2707 or Tripplite 773-869-1234

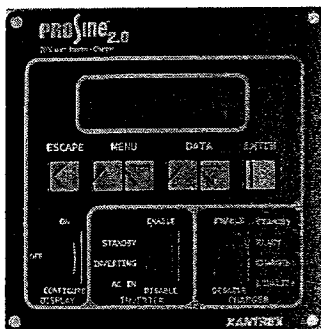

**XANTREX DISPLAY PANEL**

**DISPLAY** — Turns digital display on or off.  
**INVERTER** — Enable turns inverter on, Disable turns inverter off.  
**CHARGER** — Enable turns charger on, Disable turns charger off.  
**ESCAPE/MENU/DATA/ENTER** — For more technical information please see the Xantrex Manual.

**TRIPPLITE**

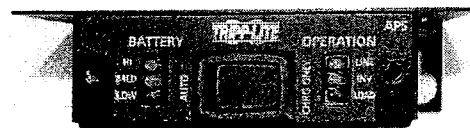

**AUTO** — Switch here to invert (12V to 110V)  
**CHARGE ONLY** — Switch here to turn inverter off.  
**NOTE** — In either above position the inverter/charger will supply 110V power and charge your auxiliary batteries — when connected to 110V hook-up or running your generator.

### INVERTER — WIRED INTO 110V SYSTEM

Note: Some items shown are options (O) that may not be included with your order.

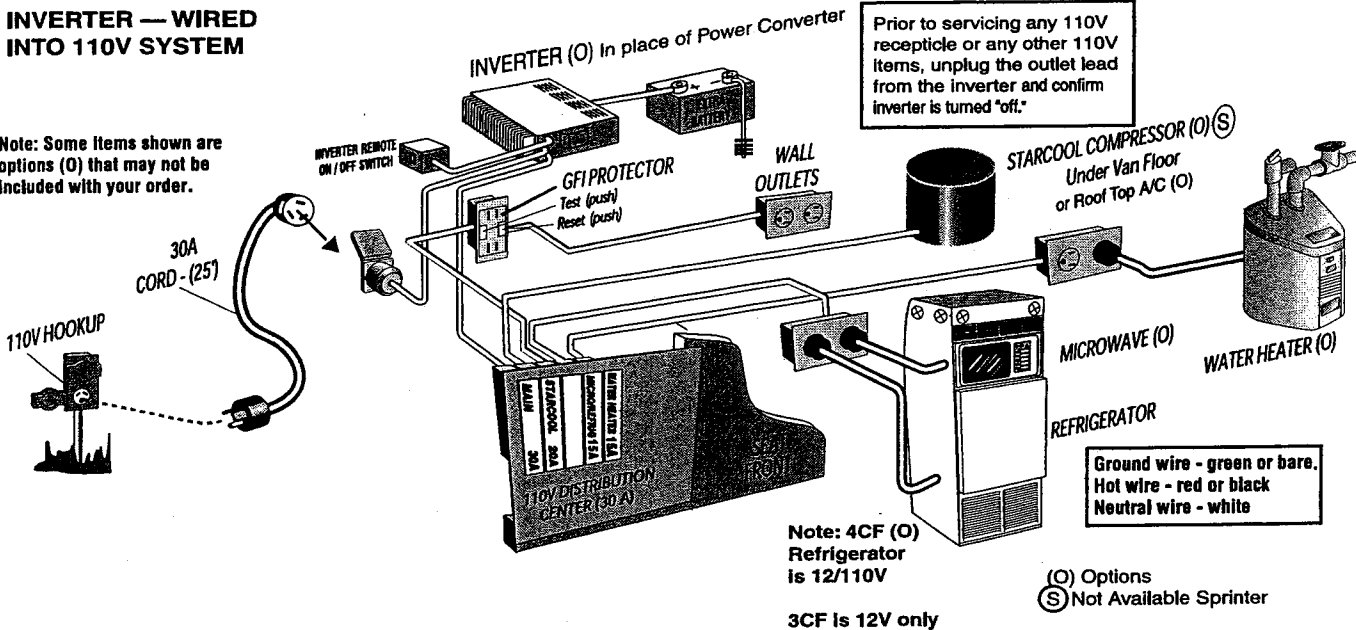

# Freeze Protection Procedures For Your FlatPlate Heat Exchanger

The potable water system in your Sportsmobile is designed to give you many years of trouble free service if maintained properly. Your Sportsmobile Owners Manual gives instructions on cleaning procedures and winterizing your potable water system on pages 10-14.

**Your entire water system is subject to damage if water left in the system freezes.**

While components we use and drain valves we install minimize this risk, you must still use care in protecting your water system by following the instructions on pages 10-14 of your Sportsmobile Owners Manual and the additional information below. Even components located inside of the cabin area will freeze if there is no heater operating to maintain temperatures above freezing.

The FlatPlate Heat Exchanger is located outside of the cabin area because it has engine coolant hoses connected to it. In the event of a hose rupture we do not want hot engine coolant entering the cabin area. You will need to drain the potable water out of the FlatPlate Heat Exchanger if it will be subject to freezing temperatures. The procedure for draining the FlatPlate Heat Exchanger is;

- Turn water pump switch “off”.
- Close the internal “shut-off” valve to FlatPlate Heat Exchanger located inside of cabinet.
- Open both drain valves located on FlatPlate Heat Exchanger, use caution as water might be hot!

If you want to have hot water while camping in freezing conditions:

- Start van engine and bring to operating temperature or start Espar Hydronic.
- Close both drain valves on the FlatPlate Heat Exchanger.
- Open the internal “shut-off” valve to the FlatPlate Heat Exchanger located inside of cabinet.
- Remember to drain water from FlatPlate Heat Exchanger before subjecting unit to freezing again.

You can use a potable water antifreeze as described on page 11 if you do not want to drain the FlatPlate Heat Exchanger. This antifreeze will also protect your holding tanks from damage.

# CP-20 and CP-30 Centrifugal Circulator Pumps

## Installation, Operation, and Maintenance

**The Concept:** CP-20 and CP-30 are centrifugal pumps designed for use in fresh or salt water (hot or cold) circulating systems. Construction is of bronze, stainless steel, or is non-metallic, so these pumps may be used to pump nearly any non flammable, non-explosive liquid.

**Installation:** Install the pump in a location that will provide generous air flow to aid in motor cooling. Fasten securely to the mount platform with four (4) 1/4" stainless steel fasteners.

Pumps are not self-priming; the installation location must assure a flooded inlet.

**Bonding:** GROCO pumps must be connected to the vessel bonding system. Use 14-gauge (or larger) stranded copper wire and a ring terminal beneath one of the bolts that holds the pump castings together to make this connection.

**Warning:** Motorized equipment must have a separate connection to the vessel DC grounding bus in accordance with ABYC, E-11, Figure-18. DO NOT make pump bonding connection in series with non-motorized equipment such as strainers or seacocks.

**Electrical:** Proper wire size is essential for proper motor and pump performance. Refer to the wire size selection chart enclosed. The orange wire is positive (+). Make electrical connections with marine grade crimp terminals.

**Operation:** Consider controlling CP-20 or CP-30 with GROCO Pump Cycle Timer PC-10 or FPC-10.

**Maintenance:** No regular maintenance is required.

**Winterization:** Freezing water within will damage the pump. Close the inlet seacock and disconnect the connecting fittings or hose to drain water. Remove the pump cover to drain water from the pump cavity.

**Plumbing:** Make plumbing connections with pipe, hose, or pipe-to-hose adaptors. Double clamp hose connections and use TFE thread tape on pipe connections.

Avoid sharp bends and sags in plumbing lines, and use full-flow fittings and hose if possible.

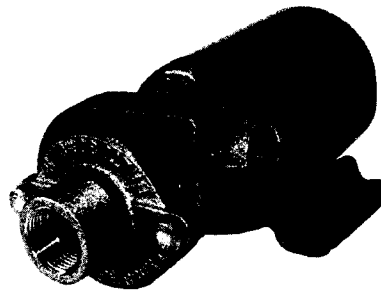

CP-20 has 3/4" NPT Inlet, Outlet is for Garden Hose or 1/2" NPT



CP-30 has replaceable motor brushes. Inlet and Outlet are the same as CP-20

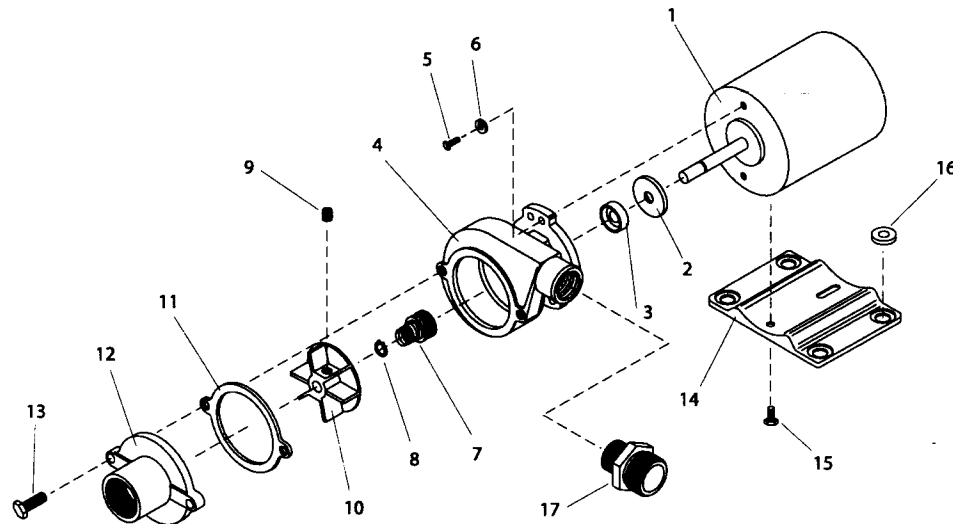

Item	Part Number	Part Name	Qty	Service Kit
1	(voltage)-B	Motor (CP-20 Series)	1	
	(voltage)-M	Motor (CP-30 Series)	1	
NS	24137901	Brushes (M series)	1	
2	SP-95	Washer	1	
3	031-075-8	Seal	1	*
4	CP-20-A	Housing	1	
5	1032X12HS	Screw	2	
6	10SS	Lockwasher	2	
7	69026	Seal Assy	1	*
8	Snap Ring-1	Snap Ring	1	*
9	14X14SET	Set Screw	1	
10	CP-55	Impeller & Set Screw	1	
11	CP-56	Gasket	1	*
12	CP-58-H	Cover	1	
13	1420X34HS	Screw	2	
14	B-200-P	Base	1	
15	1032X12HST	Screw	2	
16	B-200-G	Grommet Set (4)	1	
17	GHM500M	1/2 NPT x GH Adaptor	1	
	P-2			*



**GENERAL**

1. Your water system is a "demand" type system. When the pump switch is "on" the pump will pressurize the water lines and remain in a "stand by" mode until a faucet is opened. At that time, the pump will begin pumping water. The pump will stop when the faucet is closed.

**TO OPERATE**

1. Make sure the water tank has plenty of water in it.
2. Turn the switch "on." The pump may operate momentarily.
3. If the pump continues to operate, open a faucet and let excess air escape, then close. If the pump still continues to operate, check the water tank fill valve, located next to the water tank, and make sure its turned "off," (clockwise).
4. If the pump still continues to operate turn it off and have the water system checked.

**WHEN YOU ARE CONNECTED TO CITY WATER**

1. Turn water pump switch "off." The city water will pressurize the water lines.
2. Failure to turn switch "off" will allow the pump to take water from the tank even though you are connected to city water.

**SGW (SOMETHING GONE WRONG)**

**LOOSE WATER PUMP HEAD**

1. Any or all of the following problems can be caused by loose pump head screws.

**WATER PUMP MOTOR DOES NOT OPERATE**

1. Is the battery charge too low? Are the wires disconnected? Is the switch in the "on" position? Is the fuse good? Is the pump frozen? If so, place a lamp bulb near the pump to thaw.

**PUMP RUNS BUT WATER DOES NOT APPEAR (Most frequent problem)**

1. Is there water in the tank? Is air leaking into the inlet hose or fittings? Is the inlet line clogged? To check, remove the outlet hose and try again. If water flows the problem is further on in the system.
2. Check the fill valve to see if it is turned off all the way - **clockwise**.
3. If valve is off and pump cycles, you probably need to replace the fill valve. Contact Sportsmobile for a replacement.

**MOTOR RUNS BUT WATER SPUTTERS**

1. Indicates air getting into the lines. Check hose and clamps on the input side of the pump. Restart and allow air to clear from the lines.

**PUMP CYCLES (RAPID ON/OFF)**

1. Cycling of the pump is normal if the flow of water is restricted to less than the flow capacity of the pump. For example a faucet is partially opened. Under these conditions the pump will cycle on and off in a rhythmic interval.

**ABNORMAL CYCLING**

1. If the pump cycles on and off when all faucets are closed, something is wrong. Most likely there is a leak somewhere. Check faucets for dripping, especially the toilet valve if you have a Marine Toilet.
2. Correct any leak no matter how small. Also check the city water inlet.
3. If no leak can be detected, shut off the pump. Remove the output line. Install a 1/2" FIP pipe cap on the pump outlet fitting so there is no leak.
4. Turn the pump switch on. The pump should come on, run a few seconds and shut off. If the pump remains off, the problem is not the pump. The problem is in the system.
5. If, however, the pump goes on and off there may be a problem in the pump. There may be an internal pump leak which allows water to escape from the high pressure area back into the low pressure inlet area causing the pump to cycle. This may be caused by a valve held open by a foreign particle or by a crack in the casting.

**PUMP DOES NOT SHUT OFF**

1. The wall switch may be used for temporary control of the pump. A low battery may be the cause. Voltage should be 10.5 volts or more to the pump. If the motor runs but the pump does not switch off, there may be air in the lines or a valve problem.
2. Try Shur-Flo valve replacement kit #94-232-00. If the motor draws current but does not run, it may hum. It may be a switch problem. Try the switch replacement kit #94-230.

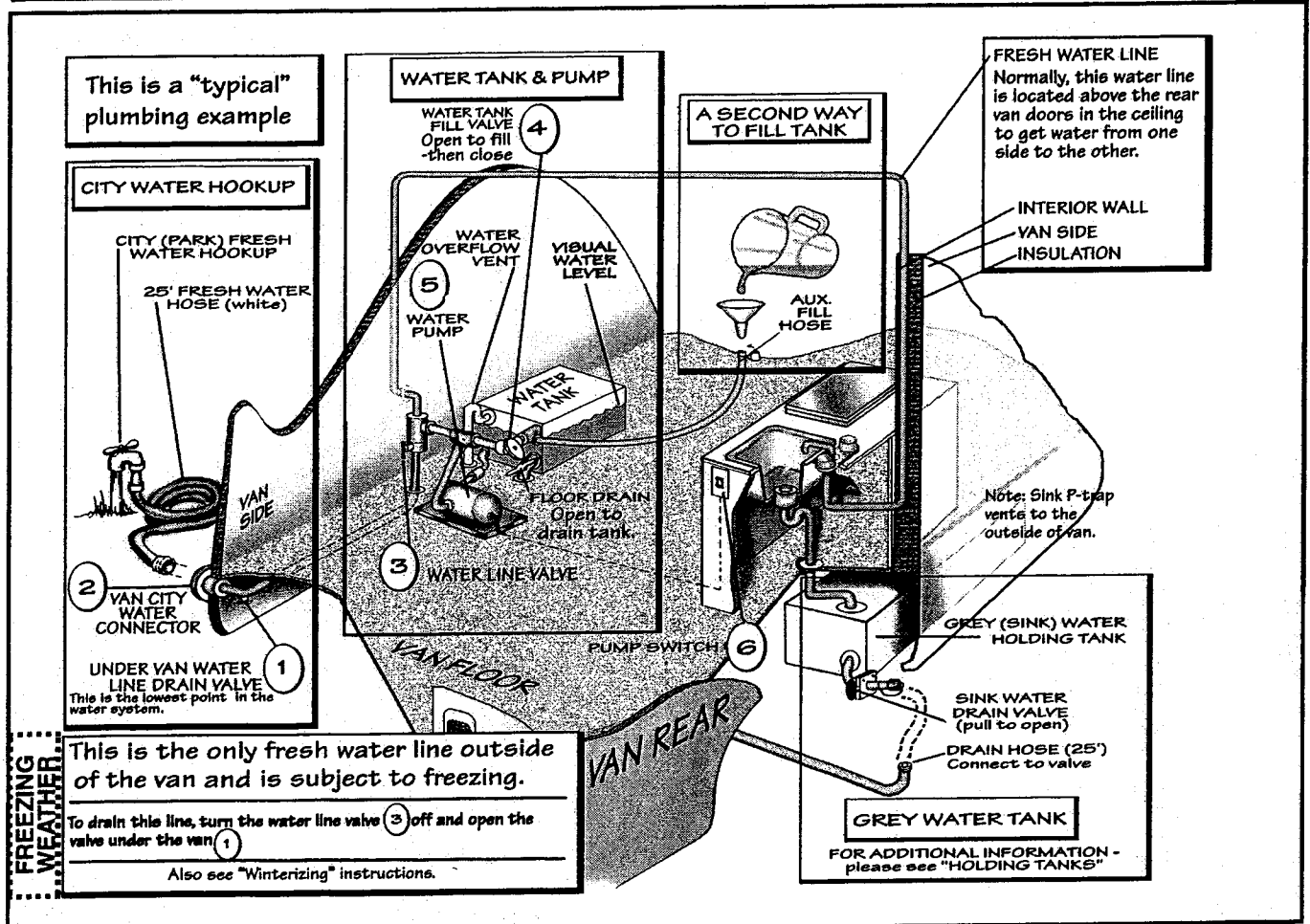

**TO CONNECT TO A CITY WATER HOOKUP**

- Water Pump — switch "off".
- Connect the fresh water hose to the city water hookup.
- Fill hose with water, then turn water "off". This will keep air out of van water lines.
- Connect hose to van (2).
- Turn city water connection back "on". You now have water to your sink and options such as the water heater, shower and marine toilet.

**TO FILL YOUR FRESH WATER TANK**

- Turn the water tank valve "on" counter-clockwise (4). When full, turn the valve "off".
- Note - the only time this valve should be "on" is when you need to fill the tank. Leave "off" at all other times.
- In the event you cannot fill your water tank with the fresh water hose, you can fill the tank with the auxiliary fill hose. You can also "flush" your tank this way. The male garden hose connection for the auxiliary fill hose has a black cap and is located by the water tank fill valve.

**TO SANITIZE YOUR WATER SYSTEM**

There are several commercial solutions approved for use. You can also prepare the solution yourself...

A. Prepare a chlorine solution using one gallon of water and 1/3-cup of household bleach (5% sodium hypochlorite solution). With water tank empty, pour one gallon of solution into tank for each 10 gallons of tank capacity. Open faucets to release air. Pressurize the system with pump until water flows, then turn pump and faucets off. Allow to stand for three hours. Drain and flush with potable fresh water.

B. To remove excessive chlorine taste or odor which may remain, prepare a solution of one quart of vinegar to five gallons of water and allow solution to agitate in water tank by vehicle motion (several days if possible). Drain tank and again flush with potable fresh water.

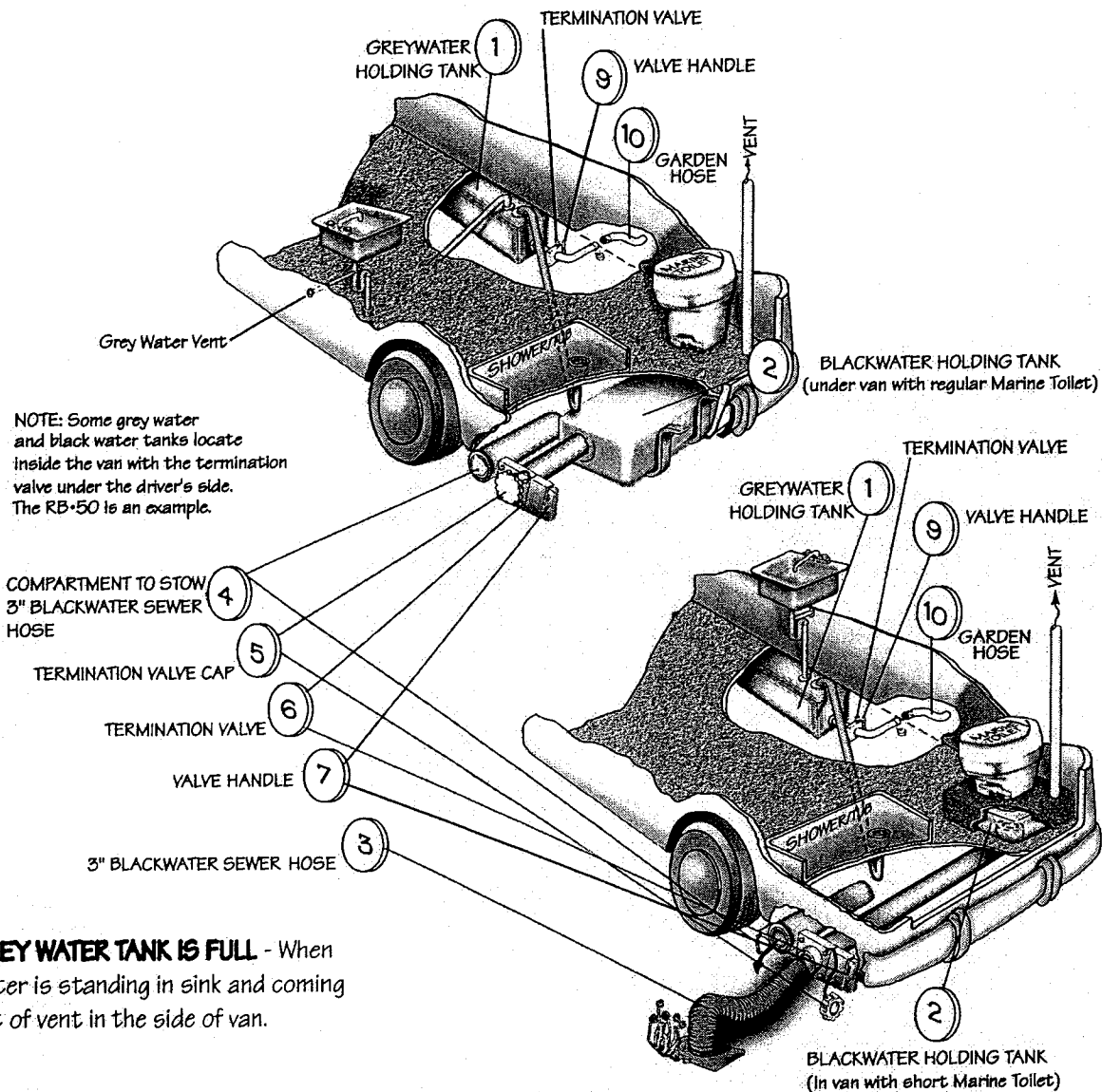

**GREY WATER TANK IS FULL** - When water is standing in sink and coming out of vent in the side of van.

**GREY WATER HOLDING TANK, FOR SINK AND SHOWER WATER**

1. The tank can be drained by removing the end cap, and pulling the valve open (9). This water can be drained into a park ground tank by connecting a garden hose (10) to the termination valve end.
2. If your Sportsmobile includes a black water holding tank, the termination valve will be on the driver's side. Depending on your floor plan - the gray water may also drain into this tank.

**BLACK WATER HOLDING TANK, FOR MARINE TOILET**

1. This tank can install under the van's floor, or inside the van depending on the floor plan.
2. A 10' long 3" sewer hose (3) - is supplied for the black water holding tank. A water line connects to the marine toilet for flushing.

**BLACK WATER HOLDING TANKS, DRAINAGE**

1. Your waste drainage system was designed to provide adequate and safe storage and/or discharge of waste materials. All materials used in fabrication of the system and appliances and fixtures connected thereto are tested and approved by a nationally recognized testing laboratory. Installation is by approved RVIA codes.
2. The drainage system basically uses properly sized ABS plastic piping and fittings connected to sinks, toilet and holding tanks and provides for their drainage to an outside termination. All fixtures incorporate the use of "P" traps to provide a water seal against entry of gases from outside connections. The Sportsmobile should be reasonably level for best operation of the system.

**GENERAL**

1. Waste holding tanks are usually dumped while connected to a sewer rise connection at a travel park. You may need to use other dump facilities from time to time. It is best to carry along various RV campground guides such as Woodalls, Rand-McNally or Good Sam. Also see [www.rvdumps.com](http://www.rvdumps.com).
2. Most of the unwanted solids build-up in the black water holding tank is due to using too little water and not flushing the tank out properly after each use. If you wish to dump a partially full tank, it is better to fill the remaining space in tank with water first to provide the volume necessary for complete flushing. Never use ammonias, alcohols or strong bleaches to clean the holding tank as they can cause damage to the plastic tank and drain lines.
3. Vehicle Movement helps liquefy solids for easier dumping of the tank. For this reason, when possible, it is always better to dump soon after road travel rather than before travel. To empty the tank, connect drain hose to the drain line termination fitting and the sewage receptor. Pull the "black water" slide valve in one slow continuous motion and secure lever.

**How to Empty Your Black Water Tank**

1. Remove the holding tank outlet cap and connect your three-inch sewer hose to the outlet of your holding tank. Extend the hose to the opening of the dump station, which is usually a hole in the ground that is slightly larger than the three-inch hose.
2. Insert your sewer hose into the dump station's hole about four to six inches. Use the hole's cover, a brick, or something heavy enough to hold the sewer hose in place so it doesn't come out of the hole.
3. Once you're sure that all is connected and held down, open your black tank valve. You'll hear the effluent flow and eventually it'll slow, then stop. Close the black tank valve.
4. Now open the gray tank valve. Again, you'll hear water flow, then slow, then stop. Close the gray tank valve.
5. At this point, you're almost done. If you want to flush and rinse your tanks once more you can do so by filling your tanks to two-thirds full and repeat the emptying process. If others are waiting to use the dump station, skip this step.
6. Recheck that both your black and gray water tank valves are closed and disconnect the sewer hose from your tank outlet. Replace the tank outlet cover. Lift the end of the sewer hose (the end you just disconnected) to completely drain the hose into the dump station. If a non-potable water hose is available, run water through the sewer hose to rinse it out. Remove the sewer hose from the dump station hold and rinse the outside of the hose, Rinse the area around the hole to ensure that any spillage has been diluted and cover the dump station hole.
7. Add about five gallons of water (about three flushes) to your black tank and then add the appropriate amount of holding tank treatment. If you use a treatment for your gray tank, do that as well.

**PLUMBING - MACERATOR PUMP (O)**

**GENERAL**

1. The macerator pump, Flojet Model 18550-000 is the ideal solution for emptying holding tanks on recreational vehicles and avoiding dump stations. The macerator section grinds waste down to a particle size of 1/8" maximum so it can easily be pumped through a 1" ID discharge hose. It will only take about 2 minutes to empty your tanks.
2. The Flojet macerator pump unit has been designed to handle waste, toilet tissue and facial tissue, It will also handle solids such as filter tip cigarettes, cigars and chunks of soft fruits or vegetables less than 1" size. It will not pump solid objects like peach pits, rags or sanitary napkins. The holding tank and pump should be flushed with water after each pumpout.

**OPERATION**

1. **Do not run pump dry.** Make sure your battery is adequately charged.
2. **Do not open both GW & BW valves at same time.**
3. Open black water (BW) valve. Pump out tank. Close BW valve.
4. Open grey water (GW) valve. Pump out tank. Close GW valve.
5. After long periods of nonuse, the macerator pump may not turn freely. Pour a cup of water down pump discharge line to help free the impeller. The motor shaft has a screw driver slot machined at the rear of the motor. This may be used to free a stuck impeller after months of nonuse.

**WINTERIZING** — See page 74

**TO DRAIN THE FRESH WATER SYSTEM**

1. **Fresh water tank** - open valve next to tank through van floor.
2. **City water connection** - open the valve next to the connection "under" the van. This is the lowest point of the complete fresh water system.
3. **Faucets** - open both.
4. **Water pump** - turn on, pump out tank and water heater (110V or propane). Let pump run a few minutes until "dry."
5. **Water pump** - to drain any remaining water out of the pump, remove the outlet hose on the pump. Turn pump on. Use a rag or towel to catch water. Reattach pump hose.
6. **110V water heater** - after the system is drained, water will remain in the heater. To drain this water, remove the lower plug.
7. **Propane water heater** - Your water heater plumbing system is equipped with a bypass kit, use it to close off the water heater, drain the water heater completely and leave the water heater closed off (out of the system) in the bypass position, particularly if you are introducing antifreeze into the plumbing system. Antifreeze can be very corrosive to the anode rod creating premature failure and heavy sediment in the tank.

**See manufacturer's instructions for any changes.**

Turn off electrical power to water heater either at the switch from the electrical element or at breaker. Shut off gas supply to water heater. Turn off pressure pump on water system. Open both hot and cold water faucets. Remove anode rod from tank.

NOTE: Be certain to refill water heater with water and remove all air from tank and lines before relighting or before turning on electric power.

**USING RV ANTIFREEZE**

1. **RV antifreeze is available** at RV stores, Good Sams, Camping World, etc., to prevent freezing of your water system. Follow the manufacturer's instructions. **WARNING - do not use "automotive antifreeze as it is toxic."**
2. **Pour RV antifreeze in fresh water tank**, turn on water pump. Open cold side of faucet until you see antifreeze, then open hot side until you see antifreeze. **If you have a shower or marine toilet**, run those until you see antifreeze. Water tank, lines and holding tanks are protected.
3. **If equipped with macerator pump**, open termination valves to allow antifreeze into pump, run pump for a few seconds until antifreeze comes out.
4. **Porta Potti** — see mfg's literature.
5. **Water heater** - **do not** run RV antifreeze into the water heater. Use the bypass valve installed to the heater to prevent this.
6. **Other items not included here** — see mfg's literature.
7. To de-winterize, follow the instructions on the RV antifreeze container.

**USING SYSTEM IN FREEZING WEATHER**

1. Water freezes at any temperature below 32°F, but the real problems of operation come at bitterly cold temperatures. Your interior water lines, water fixtures, water tanks and pump assembly are normally protected from moderate freezing as long as there is some heat in the van.
2. Pour RV antifreeze into your sink to flow into your gray water tank to help protect it. This will also protect your drain trap (P-trap). If you have a marine toilet, pour RV antifreeze into the toilet and flush into the black water tank.

**Under moderate subfreezing conditions**, antifreeze is required in the black and gray waste holding tanks. Antifreeze should be used at a 50% water and 50% antifreeze ratio or follow directions on container.

**REFILLING SYSTEM WITH FRESH WATER**

1. See page 71.

**Sportsmobile  
Service & Maintenance Schedule**

**2008 4WD Vehicle**

	Miles (Thousands)	5	10	15	20	25	30	35	40	45	50	55	60
	Kilometers (Thousands)	8	16	24	32	40	48	56	64	72	80	88	96
1	Check wheel lug nut torque (see Notice below)	x	x	x	x	x	x	x	x	x	x	x	x
2	Inspect and lubricate front wheel bearings			x			x			x			x
3	Inspect disc brake system		x		x		x		x		x		x
4	Lubricate steering linkage, check linkage, nut and pins, driveshaft U-joints, and front and rear slip-yokes	x	x	x	x	x	x	x	x	x	x	x	x
5	Lubricate caliper slide rails			x			x			x			x
6	Inspect and lubricate front axle spindle and inner needle bearing						x						x
7	Inspect hub lock lubrication						x						x
8	Check oil level & condition in front axle (Torco 85-140 GL6)		x		x		x		x		x		x
9	Change front axle oil (Torco 85-140 GL6)				x				x				x
10	Check oil level & condition in transfer case (Torco MTF GL4)		x		x		x		x		x		x
11	Change transfer case oil				x				x				x

12 **Heavy Duty Use;** When hubs & axles are submerged in water, off road, etc. maintenance schedule item 1-11 should be performed A.S.A.P.

Please refer to the Ford general maintenance schedule for additional information. This document takes preference.

NOTE: Repeat maintenance schedule for each successive 60,000 mile intervals.

**NOTICE!!!**

**DRIVER - DEALER - OWNER  
CHECK WHEEL LUG NUTS**

1. Check wheel lug nuts at 50, 100 and 300 miles. Torque to 140 ft lbs.
2. Check lug nuts periodically afterwards.
3. Before a trip, always check tire pressure.
4. After changing or rotating tires repeat #1
5. Alignment specifications; see attached specification sheet.

**Sportsmobile West**

3631 S. Bagley Ave.  
Fresno, CA 93725  
(559) 233-8267  
Fax (559) 486-8267

# **Sportsmobile**

## **2008 4WD Vehicle**

### **Sportsmobile Dynatrac Front Axle Spare Parts List Pro Rock 5500 lb Rated**

Tie Rod Ends:            Moog # ES2082R            Dynatrac # DA60-3304-T  
                                 Moog # ES2083L            Dynatrac # DA60-3304-U

Ball Joints:                Spicer # 707238X

Brake Caliper/Pads: 2008 E-350

Brake Line:  
    Left                    Ford # 2C2Z-2078-BB  
    Right                   Ford # 2C2Z-2078-BA

Brake Rotor: 1995-98 Ford F350/Auto Specialty AR8553/ Dynatrac #DA601125-D

Wheel Studs:             Dynatrac # DA60-1107-AL / Dorman # 610-283

Timken Wheel Bearings:  
    Inner:                 387A                         Dynatrac # DA60-1244-A  
    Inner Race:         382A                         Dynatrac # DA60-4222-B  
    Outer:                 LM104949                     Dynatrac # DA60-1244-B  
    Outer Race:         LM104911                     Dynatrac # DA602-4222-C  
    Grease Seal: 48816                     Dynatrac # DA60-1175-D

Spindle Spanner nut:     Spicer # 33732                 Dynatrac #DA60-1195-A  
Lock washer:               Spicer #33733                 Dynatrac #DA60-1198-A

Axle Shaft u-joint:        Spicer # 5-332X                 Dynatrac #DA60-3249-A

Inner Axle Seal:            36487                             Dynatrac #DA60-3254-A

Warn Premium Manual Hubs:     Warn #38826

Yoke: 1350 Series Spicer# 3-4-5731X

ABS Sensor Driver Side: GM 15990503  
ABS Sensor Passenger Side: GM 15990504

**Made in the USA**  
[www.sportsmobile.com](http://www.sportsmobile.com)

**Sportsmobile Inc**  
250 Court.  
Huntington, IN 46750  
(260) 356-5435  
Fax (260) 358-0328

**Sportsmobile Texas**  
9805 Gray Blvd  
Austin, TX 78758  
(512) 835-4409  
Fax (512) 835-1293

**Sportsmobile West**  
3631 S. Bagley Ave.  
Fresno, CA 93725  
(559) 233-8267  
Fax (559) 486-8267

